

2.2Nm Stepper Motor



**INFORMATION IS SPECIFIC TO OUR PRODUCTS AND CAN CAUSE
DAMAGE IF USED WITH NONE COMPATIBLE PRODUCTS SO PLEASE
CHECK WITH YOUR SUPPLIER FOR COMPATIBILITY**

These drawings are supplied as a guide no guarantees are implied or given. Caution when wiring and check with a qualified professional if unsure. It is your responsibility to check you have complied with your local legislation as to safety requirements for your country as machines can cause injury to users.

By using these diagrams you agree to the above safety warning.

Documentation will be updated amended at the discretion of CNC4YOU Ltd.

SPECIFICATIONS MODEL 57HS82-3008B

PHASE	STEP ANGLE	CONNECTION TYPE	CURRENT	RESISTANCE	INDUCTANCE	HOLDING TORQUE		VOLTAGE	WEIGHT
	DEG/STEP		AMPS	ohms $\pm 10\%$	mH $\pm 20\%$	Nm	oz in	VOLTS	KG
2	1.8	PARALLEL	4.2	0.70	2.5	2.2	311.5	2.94V	1.2
2		SERIES	2.1	2.8	10.0	2.2	311.5	5.88V	
4		UNIPOLAR	3.0	1.4	2.5	1.6	226.6	4.20V	

Dimension:
Unit=mm

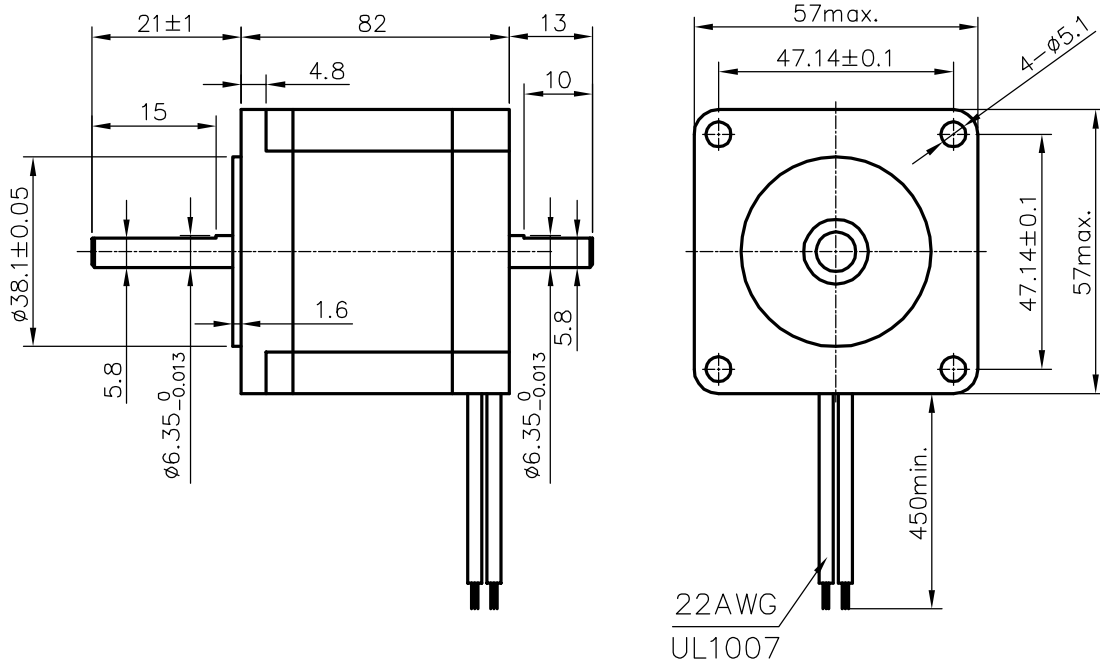

WIRING DIAGRAM

Bipolar Series

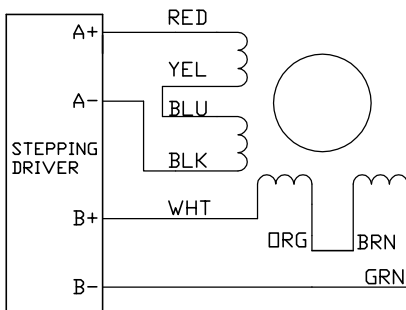

Bipolar Parallel

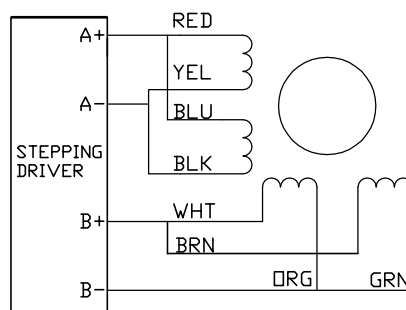

Unipolar

