

SSD1928

Advance Information

JPEG Codec
Camera and video input port
SD interface
256K Embedded Display SRAM
Image Processor
CMOS

This document contains information on a product under development. Solomon Systech reserves the right to change or discontinue this product without notice.

<http://www.solomon-systech.com>

SSD1928

Rev 1.0

P 1/32

Dec 2006

Copyright © 2006 Solomon Systech Limited



SOLOMON
SYSTECH

CONTENTS

1	GENERAL DESCRIPTION	6
2	FEATURES.....	6
2.1	CAMERA INPUT PORT	6
2.2	HARDWARE JPEG CODEC	6
2.3	2D GRAPHIC ENGINE	7
2.4	LCD GRAPHIC CONTROLLER.....	7
2.5	LCD PANEL INTERFACE	7
2.6	HOST MCU INTERFACE	8
2.7	MMC/SD INTERFACE.....	8
2.8	I/O INTERFACE	8
2.9	MISCELLANEOUS	8
2.10	PACKAGE.....	8
3	ORDERING INFORMATION.....	8
4	BLOCK DIAGRAM	9
5	PIN ARRANGEMENT.....	10
5.1	128 PIN LQFP.....	10
6	PIN DESCRIPTIONS.....	12
6.1	GLOBAL SIGNAL	12
6.2	MCU INTERFACE.....	13
6.3	DISPLAY INTERFACE.....	14
6.4	CMOS CAMERA INTERFACE.....	15
6.5	MMC/SD/SDIO INTERFACE	15
6.6	CONFIGURATION.....	16
6.7	MISCELLANEOUS	16
6.8	POWER AND GROUND	16
6.9	SUMMARY OF CONFIGURATION	17
6.10	HOST BUS INTERFACE PIN MAPPING	18
6.11	LCD INTERFACE PIN MAPPING.....	18
6.12	DATA BUS ORGANIZATION.....	18
7	FUNCTIONAL BLOCK DESCRIPTIONS	20
7.1	PHASE LOCK LOOP (PLL).....	20
7.2	EMBEDDED MEMORY	20
7.3	MCU INTERFACE.....	21
7.3.1	<i>Generic #1 addressing Mode.....</i>	<i>21</i>
7.3.2	<i>Generic #2 addressing Mode.....</i>	<i>22</i>
7.3.3	<i>8080 Indirect addressing Mode.....</i>	<i>23</i>
7.4	REGISTERS.....	28
7.5	JPEG ENCODER/DECODER	28
7.6	IMAGE CAPTURE INTERFACE	28
7.7	2D ENGINE	28
7.8	DISPLAY INTERFACE.....	28
7.9	MMC/SD/SDIO INTERFACE	28
7.10	GENERAL PURPOSE INPUT/OUTPUT (GPIO)	28
8	MAXIMUM RATINGS	29
9	DC CHARACTERISTICS	30
10	AC CHARACTERISTICS.....	31

10.1	CLOCK TIMING	31
10.1.1	<i>Input Clocks</i>	31
10.2	CPU INTERFACE TIMING	32
10.2.1	<i>Generic #1 Interface Timing</i>	32
10.2.2	<i>Generic #2 Interface Timing (e.g. ISA)</i>	34
10.2.3	<i>8080 Indirect Interface Timing</i>	36
11	APPLICATION EXAMPLES	37
11.1	APPLICATION DIAGRAM	37
12	PSEUDO-CODE EXAMPLES FOR INDIRECT ADDRESS MODE.....	40
12.1	8080 INDIRECT ADDRESS MODE	40
13	PACKAGE INFORMATION.....	45
13.1	PACKAGE MECHANICAL DRAWING FOR 128 PINS LQFP	45

TABLES

TABLE 3-1 : ORDERING INFORMATION	8
TABLE 5-1 : LQFP PIN ASSIGNMENT TABLE	11
TABLE 6-1 : HOST INTERFACE PIN DESCRIPTIONS	12
TABLE 6-2 : MCU INTERFACE PIN DESCRIPTIONS	13
TABLE 6-3 : DISPLAY INTERFACE PIN DESCRIPTIONS	14
TABLE 6-4 : CMOS CAMERA INTERFACE PIN DESCRIPTIONS	15
TABLE 6-5 : MMC/SD/SDIO INTERFACE PIN DESCRIPTIONS	15
TABLE 6-6 : CONFIGURATION PIN DESCRIPTIONS	16
TABLE 6-7 : MISCELLANEOUS PIN DESCRIPTIONS	16
TABLE 6-8 : POWER AND GROUND PIN DESCRIPTIONS	16
TABLE 6-9 : SUMMARY OF CONFIGURATION PINS	17
TABLE 6-10 : HOST BUS INTERFACE PIN MAPPING.....	18
TABLE 6-11 : LCD INTERFACE PIN MAPPING	18
TABLE 6-12 : DATA BUS ORGANIZATION	18
TABLE 6-13 : PIN STATE SUMMARY	19
TABLE 8-1: ABSOLUTE MAXIMUM RATINGS	29
TABLE 8-2 : RECOMMENDED OPERATING CONDITIONS	29
TABLE 9-1 : ELECTRICAL CHARACTERISTICS FOR IOV _{DD} = 3.3V TYPICAL	30
TABLE 10-1 : CLOCK INPUT REQUIREMENTS FOR CLKI	31
TABLE 10-2 : OSCILLATOR CLOCK INPUT REQUIREMENTS FOR CLKI2	31
TABLE 10-3 : GENERIC #1 INTERFACE TIMING	33
TABLE 10-4 : GENERIC #2 INTERFACE TIMING	35
TABLE 10-12 : 8080 INTERFACE TIMING	36

FIGURES

FIGURE 4-1 : SSD1928 BLOCK DIAGRAM.....	9
FIGURE 5-1 : PINOUT DIAGRAM – 128 PIN LQFP (TOPVIEW).....	10
FIGURE 7-1 : CIRCUIT FOR PLL ENABLE	20
FIGURE 7-2 : GENERIC #1 INTERFACE TIMING	21
FIGURE 7-3 : GENERIC #2 INTERFACE TIMING	22
FIGURE 7-7 : 8080 16 BIT INTERFACE TIMING (WRITE CYCLE).....	24
FIGURE 7-8 : 8080 16 BIT INTERFACE TIMING (READ CYCLE)	25
FIGURE 7-9 : 8080 8 BIT INTERFACE TIMING (WRITE CYCLE).....	26
FIGURE 7-10 : 8080 8 BIT INTERFACE TIMING (READ CYCLE)	27
FIGURE 10-1 : GENERIC #1 INTERFACE TIMING	32
FIGURE 10-2 : GENERIC #2 INTERFACE TIMING	34
FIGURE 10-10 : 8080 INTERFACE TIMING	36
FIGURE 11-1 : TYPICAL SYSTEM DIAGRAM (GENERIC #1 BUS)	37
FIGURE 11-2 : TYPICAL SYSTEM DIAGRAM (GENERIC #2 BUS)	38
FIGURE 11-3 : TYPICAL SYSTEM DIAGRAM (INDIRECT 8080 16 BIT BUS).....	39

1 GENERAL DESCRIPTION

SSD1928 is an image processor designed for advanced car AV device with image capture and process features.

It offers camera or DVD input port, image processing unit and hardware JPEG codec to encode the captured image into JPEG file. The files can be saved into SD/MMC card through SD interface. The JPEG file is retrieved back from SD/MMC card, decoded and displayed on LCD panel through LCD interface. This interface supports various kinds of LCD panel like STN, CSTN and TFT.

The LCD controller of SSD1928 supports LCD panel for mobile phone with size, for example, 176x220 and 240x160 resolution at color depth 1, 2, 4, 8, 16 and 32 bit-per-pixel (bpp). For 16 and 32 bpp, SSD1928 provides 2D graphics acceleration features like virtual display, image rotation, cursor display, line drawing, BitBLT with raster operation, color fill, color expansion etc.

SSD1928 is able to interface different type of generic microcontrollers that are popular in handheld devices market. It also support indirect addressing mode which can minimize the pin count of control signals.

Internal PLLs is built such that only single clock is required for SSD1928 to generate clocks for blocks with various clock speed requirement.

With advanced power management design, SSD1928 is suitable for low power consumption and advanced image applications like car AV product etc. The SSD1928 is available in LQFP package.

2 FEATURES

The main features of the SSD1928 are as follows:

2.1 Camera input port

- Digital signal input and format
 - a. Support 8-bit YUV422 CCIR601, CCIR656
 - b. Support progressive video signal only
 - c. Capture still image size up to 2.0M pixel resolution
 - d. Max input frame frequency: 30fps at 2.0M pixel resolution
- Scaling
 - a. Support fix size low quality decimation (1, 2, 4, 8, 16)
- Image Preview
 - a. Support cropping and decimation for preview up to QVGA (320x240) size
- Color conversion
 - a. For JPEG encoding, only YUV input source is supported
 - b. Fix YUV -> RGB color conversion implementation from YUV422 -> RGB565 and YUV422 -> RGB888 format (32-bit, including 8-bit alpha blending value)
 - c. Y, U and V components can be adjusted to set brightness and contrast.

2.2 Hardware JPEG Codec

- Hardware codec to encode and decode JPEG image with variable size up to 1280 x 1024.
- JPEG codec is consisted of the following hardware module
 - a. Discrete Cosine Transform (DCT) and Inverse Discrete Cosine Transform (iDCT)

- b. Quantization calculation with table downloadable by software
 - c. Zigzag and run-length coding
 - d. Huffman encoding and decoding with table downloadable by software
- For viewing JPEG image on LCD panel, the JPEG decoder can decimate and crop the image such that the length is in multiple of 8.

2.3 2D Graphic Engine

- Screen panning and scrolling – virtual display mode
- Image rotation including 0, 90, 180, 270 degree
- Two cursors with three colors and transparency selection. Cursor blinking is available
- Line drawing
- Rectangle drawing
- Ellipse drawing
- Bit block transfer (BitBLT)
 - a. Host to frame buffer
 - b. Frame buffer to frame buffer
 - c. Total 256 three-operand raster operations (ROP3) working with BitBLT
 - d. Pattern BitBLT: Source image is repeatedly filled up destination block
 - e. Stretch BitBLT: Stretch the source image to a destination larger or smaller than the source
 - f. Color Expansion: Monochrome color is expanded to either background or foreground color.
 - g. Color Conversion: Source color is converted between RGB and YUV to destination block -> YUV overlay RGB background / RGB overlay YVU background.
 - h. Color Fill: Fill a rectangular block with a single color.

2.4 LCD Graphic Controller

- Support 1, 2, 4, 8, 16 and 32 bit-per-pixel (bpp) color depth
- In 32bpp mode, each pixel is consisted of 8-bit red, 8-bit green, 8-bit blue and 8-bit alpha channel for controlling the transparency of the image.
- In 1, 2, 4, 8bpp mode, it can display still image and has no 2D graphic engine feature available.
- Arbitrary image size supported up to horizontal resolution of 512

2.5 LCD Panel Interface

- Support the following type of LCD panels:
 - a. Monochrome and color STN 4/8 bit LCD interface
 - b. 8 bit Serial TFT interface
 - c. 8 bit Delta panel with sub-pixel accuracy algorithm
 - d. Smart LCD through SPI and 8-bit MCU (8080, 6800) interface
- For STN and CSTN panel, spatial and dynamic dithering is available to increase color depth.
 - a. 16 gray shades for each color component when applying frame rate control only
 - b. 64 gray shades for each color component when applying frame rate control and dithering
- LCD panel power on and off sequencing

2.6 Host MCU interface

- Support the following MCU interface
 - a. SRAM interface (e.g. generic ARM core type MCU)
 - b. ISA interface for MCU like NEC MIPS
 - c. 8/16 bits 8080 indirect addressing mode
- Support synchronous and asynchronous interface communication
- Memory mapped I/O
- Big/Little endian support

2.7 MMC/SD Interface

- Compatible with “The MultiMedia Card System Specification version 3.0”
- Compatible with “SD Memory Card Specification version 1.0” and “SDIO Card Specification version 1.0”
- Block transfer from/to external host
- Block transfer from/to internal memory
- Supports many SD functions including multiple I/O and combined I/O and memory

2.8 I/O Interface

- I2C master to control CMOS sensor
- 5 GPIOs

2.9 Miscellaneous

- Embedded 256K bytes SRAM
- Single clock input
- Integrated PLL
- 1.8V core voltage with built in regulator for single voltage input
- Advanced power management to cut off the power for modules that are idle.

2.10 Package

- 128-pin LQFP package

3 ORDERING INFORMATION

Table 3-1 : Ordering Information

Ordering Part Number	Package Form
SSD1928QL9	128 LQFP

4 BLOCK DIAGRAM

Figure 4-1 : SSD1928 Block Diagram

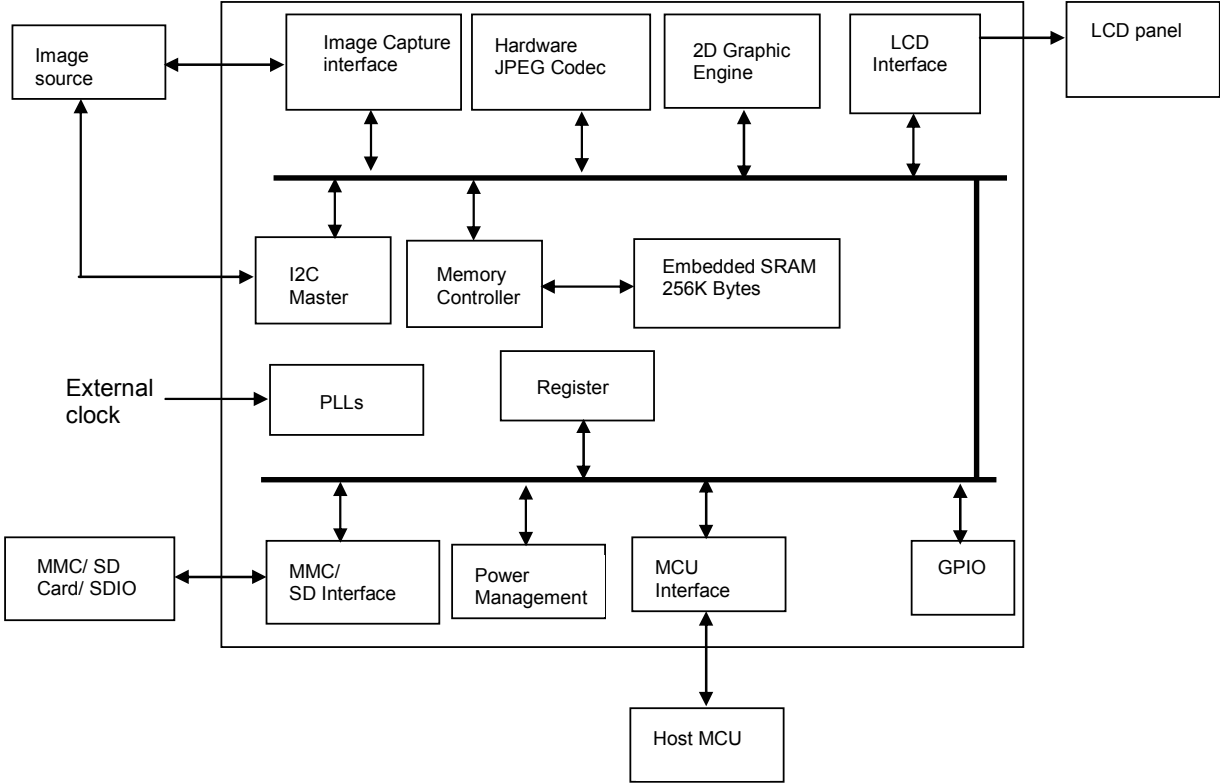

5 PIN ARRANGEMENT

5.1 128 pin LQFP

Figure 5-1 : Pinout Diagram – 128 pin LQFP (Topview)

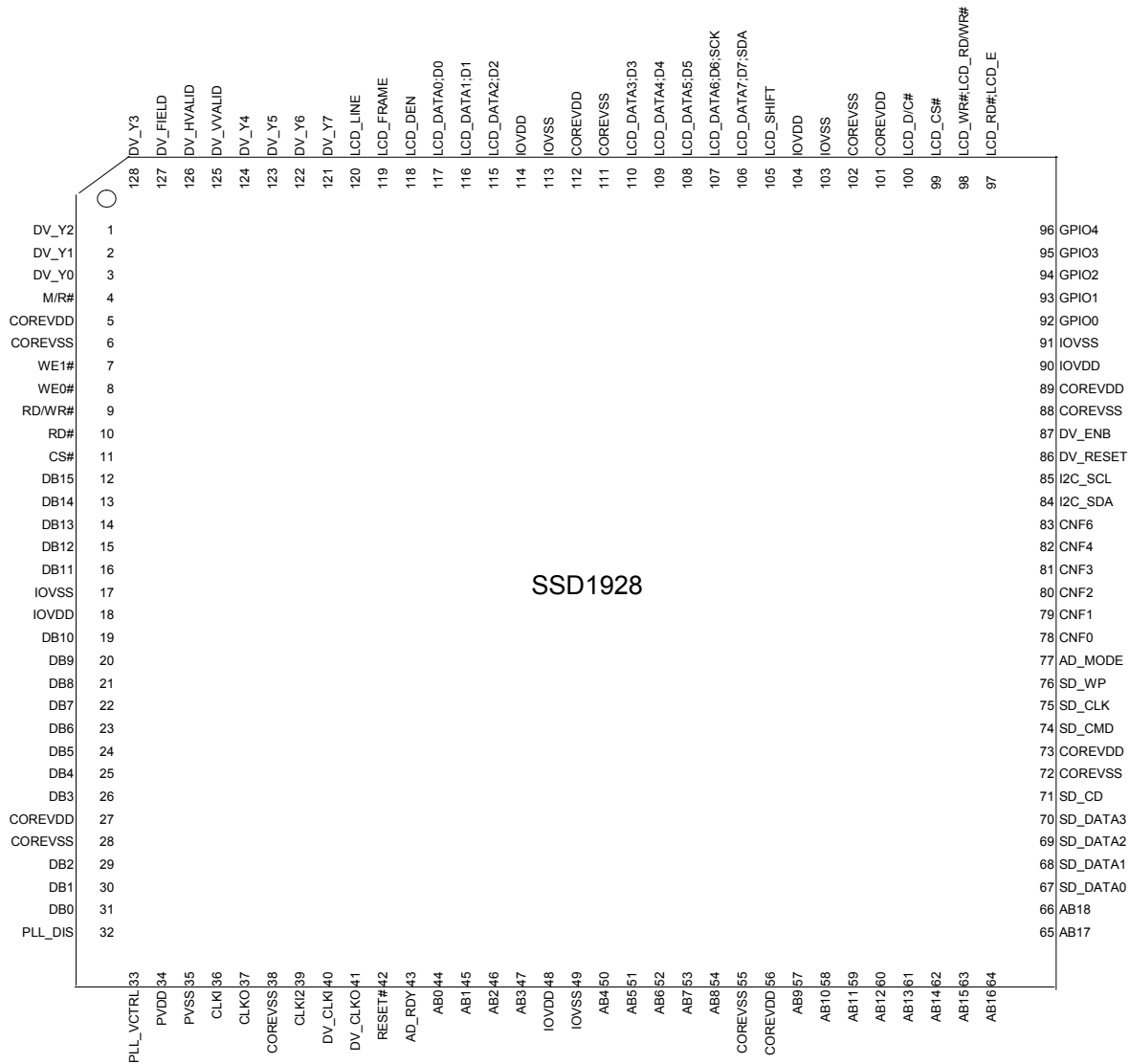

Table 5-1 : LQFP Pin Assignment Table

Pin #	Signal Name	Pin #	Signal Name	Pin #	Signal Name	Pin #	Signal Name
1	DV_Y2	33	PLL_VCTRL	65	AB17	97	LCD_RD#;LCD_E
2	DV_Y1	34	PVDD	66	AB18	98	LCD_WR#;LCD_RD/WR#
3	DV_Y0	35	PVSS	67	SD_DATA0	99	LCD_CS#
4	M/R#	36	CLKI	68	SD_DATA1	100	LCD_D/C#
5	COREVDD	37	CLKO	69	SD_DATA2	101	COREVDD
6	COREVSS	38	COREVSS	70	SD_DATA3	102	COREVSS
7	WE1#	39	CLKI2	71	SD_CD	103	IOVSS
8	WE0#	40	DV_CLKI	72	COREVSS	104	IOVDD
9	RD/WR#	41	DV_CLKO	73	COREVDD	105	LCD_SHIFT
10	RD#	42	RESET#	74	SD_CMD	106	LCD_DATA7;D7; SDA
11	CS#	43	TESTO	75	SD_CLK	107	LCD_DATA6;D6; SCK
12	DB15	44	AB0	76	SD_WP	108	LCD_DATA5;D5
13	DB14	45	AB1	77	AD_MODE	109	LCD_DATA4;D4
14	DB13	46	AB2	78	CNF0	110	LCD_DATA3;D3
15	DB12	47	AB3	79	CNF1	111	COREVSS
16	DB11	48	IOVDD	80	CNF2	112	COREVDD
17	IOVSS	49	IOVSS	81	CNF3	113	IOVSS
18	IOVDD	50	AB4	82	CNF4	114	IOVDD
19	DB10	51	AB5	83	CNF6	115	LCD_DATA2;D2
20	DB9	52	AB6	84	I2C_SDA	116	LCD_DATA1;D1
21	DB8	53	AB7	85	I2C_SCL	117	LCD_DATA0;D0
22	DB7	54	AB8	86	DV_RESET	118	LCD_DEN
23	DB6	55	COREVSS	87	DV_ENB	119	LCD_FRAME
24	DB5	56	COREVDD	88	COREVSS	120	LCD_LINE
25	DB4	57	AB9	89	COREVDD	121	DV_Y7
26	DB3	58	AB10	90	IOVDD	122	DV_Y6
27	COREVDD	59	AB11	91	IOVSS	123	DV_Y5
28	COREVSS	60	AB12	92	GPIO0	124	DV_Y4
29	DB2	61	AB13	93	GPIO1	125	DV_VVALID
30	DB1	62	AB14	94	GPIO2	126	DV_HVALID
31	DB0	63	AB15	95	GPIO3	127	DV_FIELD
32	PLL_DIS	64	AB16	96	GPIO4	128	DV_Y3

6 PIN DESCRIPTIONS

Key:

I = Input
 O = Output
 IO = Bi-directional (input / output)
 P = Power pin
 AN = Analog
 LIS = LVCMOS Schmitt input
 LB2 = LVCMOS IO buffer (8mA/-8mA at 3.3V)
 LB3 = LVCMOS IO buffer (16mA/-16mA at 3.3V)
 LO1 = LVCMOS output buffer (2mA/-2mA at 3.3V)
 LO2 = LVCMOS output buffer (4mA/-4mA at 3.3V)
 LO3 = LVCMOS output buffer (16mA/-16mA at 3.3V)
 LT2 = Tri-state output buffer (8mA/-8mA at 3.3V)
 Hi-Z = High impedance

6.1 Global Signal

Table 6-1 : Host Interface Pin Descriptions

Pin Name	Type	LQFP Pin #	Cell	RESET# State	Description
CLKI2	I	39	LIS	-	This pin can be used as clock source input when PLL is disabled. When synchronized MCU interface is selected, connect the bus clock to CLKI2 and disable the PLL by connecting the PLL_DIS pin to IOV _{DD} . If the PLL is enabled, CLKI2 has to be pull-up or pull-down.
CLKI, CLKO	IO	36, 37	AN	-	These two pins are the source clock of internal PLL. It accepts clock frequency from 2MHz to 4MHz. The clock source can be either oscillator or crystal. If 4-pin oscillator or a slow clock source is available, please connect the output of oscillator or the clock source to CLKI and leave the CLKO pin floating.
PLL_DIS	I	32	LIS	-	PLL disable control pin. PLL_DIS = IOV _{DD} , PLL disabled (When PLL is disabled, the master clock is directly fed from CLKI2 pin) PLL_DIS = IOV _{SS} , PLL enabled
PLL_VCTRL	I	33	AN	-	Control for PLL. If internal PLL is selected, RC circuit should be connected. Refer to 7.1. Leave this pin floating if PLL is disabled.
RESET#	I	42	LIS	-	Master chip reset. Active low input to set all internal registers to the default state and to force all signals to their inactive states. It is recommended to place a 0.1µF capacitor to V _{SS} . Note (1) When reset state is released (RESET# = "H"), normal operation can be started after 3 MCLK period.

6.2 MCU Interface

Table 6-2 : MCU Interface Pin Descriptions

Pin Name	Type	LQFP Pin #	Cell	RESET# State	Description
AB0	I	44	LIS	0	This input pin has multiple functions. <ul style="list-style-type: none"> For Generic #1, this pin is not used and should be connected to V_{SS}. For Generic #2, this is an input of system address bit 0 (A0). For 8080, this pin is not used and should be connected to V_{SS}.
AB[18:4, 2, 1]	I	45-46, 50-54, 57-66	LIS	0	System address bus bits 18-4, 2, 1 for direct address mode. For 8080, those pins are not used and should be connected to V _{SS} .
AB[3]	I	47	LIS	0	This input pin has multiple functions. <ul style="list-style-type: none"> System address bus bit 3 for direct address mode For 8080, this pin is used as data / command select, D/C#.
DB[15:0]	IO	12-16, 19-26, 29-31	LB2	Hi-Z	Bi-directional system data bus 15:0.
WE0#	I	8	LIS	1	This input pin has multiple functions. <ul style="list-style-type: none"> For Generic #1, this is an input of the write enable signal for the lower data byte (WE0#). For Generic #2, this is an input of the write enable signal (WE#). For 8080, this is an input of write enable signal, WR#
WE1#	I	7	LIS	1	This input pin has multiple functions. <ul style="list-style-type: none"> For Generic #1, this is an input of the write enable signal for the upper data byte (WE1#). For Generic #2, this is an input of the byte enable signal for the high data byte (BHE#). For 8080, this pin is not used and should be connected to V_{SS}.
CS#	I	11	LIS	1	Chip select input.
M/R#	I	4	LIS	0	<ul style="list-style-type: none"> For 8080, this pin is not used and should be connected to V_{SS}. For other interfaces, this input pin is used to select the display buffer or internal registers of the SSD1928. M/R# is set high to access the display buffer and low to access the registers.
RD/WR#	I	9	LIS	1	This input pin has multiple functions. <ul style="list-style-type: none"> For Generic #1, this is an input of the read signal for the upper data byte (RD1#). For Generic #2, this pin must be tied to IOV_{DD}. For 8080, this pin is not used and should be connected to V_{SS}.

Pin Name	Type	LQFP Pin #	Cell	RESET# State	Description
RD#	I	10	LIS	1	This input pin has multiple functions. <ul style="list-style-type: none"> For Generic #1, this is an input of the read signal for the lower data byte (RD0#). For Generic #2, this is an input of the read command (RD#). For 8080, this is an input of read enable signal, RD#

See Table 6-10 : Host Bus Interface Pin Mapping for summary.

6.3 Display Interface

Table 6-3 : Display Interface Pin Descriptions

Pin Name	Type	LQFP Pin #	Cell	RESET# State	Description
LCD_DATA[5:0];D[5:0]	O	108-110, 115-117	LO3	0	If RGB dump panel is selected, those pins are RGB dump data bits 5-0. If MCU smart parallel panel is selected, those pins are data bits 5-0 If MCU smart serial panel is selected, those signals are not in used.
LCD_DATA6;D6;SCK	O	107	LO3	0	If RGB dump panel is selected, this pin is RGB dump data bit 6. If MCU smart parallel panel is selected, this pin is data bit 6 If MCU smart serial panel is selected, this pin becomes serial clock signal, SCK.
LCD_DATA7;D7;SDA	O	106	LO3	0	If RGB dump panel is selected, this pin is RGB dump data bit 7. If MCU smart parallel panel is selected, this pin is data bit 7 If MCU smart serial panel is selected, this pin becomes serial data signal, SDA.
LCD_FRAME	O	119	LO3	0	Frame Pulse (vertical sync)
LCD_LINE	O	120	LO3	0	Line Pulse (horizontal sync)
LCD_SHIFT	O	105	LO3	0	Shift Clock
LCD_DEN	O	118	LO3	0	This output pin has multiple functions. <ul style="list-style-type: none"> Display enable (LDEN) for TFT panels LCD backplane bias signal (MOD) for all other LCD panels
LCD_D/C#	O	100	LO3	0	If RGB dump panel is selected, this signal is not in used. If MCU smart parallel and serial panel is selected, this signal is data/command select, D/C#.
LCD_CS#	O	99	LO3	0	If RGB dump panel is selected, this signal is not in used. If MCU smart parallel and serial panel is selected, this signal is chip select, CS#.
LCD_WR#;LCD_R/W#	O	98	LO3	0	If RGB dump panel is selected, this signal is not in used If MCU smart parallel 8080 panel is selected, this signal is WR#. If MCU smart parallel 6800 panel is selected, this signal is R/W#. If MCU smart serial panel is selected, this signal is

					not in used.
LCD_RD#,LCD_E	O	97	LO3	0	If RGB dump panel is selected, this signal is not in used. If MCU smart parallel 8080 panel is selected, this signal is RD#. If MCU smart parallel 6800 panel is selected, this signal is E. If MCU smart serial panel is selected, this signal is not in used.

See Table 6-11 : LCD Interface Pin Mapping for summary.

6.4 CMOS Camera Interface

Table 6-4 : CMOS Camera Interface Pin Descriptions

Pin Name	Type	LQFP Pin #	Cell	RESET# State	Description
DV_CLKI	I	40	LIS	-	Video clock input from video module
DV_CLKO	O	41	LO3	0	Video clock output to video module
DV_Y[7:0]	I	121-124, 128, 1-3	LIS	-	8 bits Luminance/Chrominance data input
DV_FIELD	I	127	LIS	-	Odd / Even field input
DV_HVALID	I	126	LIS	-	Horizontal valid, sometimes will be used as Horizontal SYNC input
DV_VVALID	I	125	LIS	-	Vertical valid, sometimes will be used as Vertical SYNC input
DV_ENB	O	87	LO2	0	Video module enable
DV_RESET	O	86	LO1	0	Video module reset
I2C_SDA	IO	84	LB2	-	I2C serial data. A pull-up resistor should be used to resolve any data contention issues.
I2C_SCL	IO	85	LB2	-	I2C serial clock. A pull-up resistor should be used to resolve any data contention issues.

6.5 MMC/SD/SDIO Interface

Table 6-5 : MMC/SD/SDIO Interface Pin Descriptions

Pin Name	Type	LQFP Pin #	Cell	RESET# State	Description
SD_CLK	O	75	LO3	0	SD clock
SD_CMD	IO	74	LB2	-	SD command
SD_DATA[3:0]	IO	67-70	LB2	-	SD data[3:0] SD_DATA[3:1] are not used for 1 bit SD or MMC
SD_CD	I	71	LIS	-	SD card inserted
SD_WP	I	76	LIS	-	SD card write protected

6.6 Configuration

Table 6-6 : Configuration Pin Descriptions

Pin Name	Type	LQFP Pin #	Cell	RESET # State	Description
CNF[6,4:0] I, AD_MOD E	I	77-83	LIS	—	These inputs are used to configure the SSD1928 – see Table 6-9 : Summary of Configuration pins. Note ⁽¹⁾ These pins are used for configuration of the SSD1928 and must be connected directly to IOV _{DD} or V _{SS} .

6.7 Miscellaneous

Table 6-7 : Miscellaneous Pin Descriptions

Pin Name	Type	LQFP Pin #	Cell	RESET # State	Description
GPIO[4:0]	IO	92-96	LB3	0	General Purpose IO. Those GPIO signals can be programmed as LCD control which sync with LCD signals.
TESTO	O	43	LO3	0	Test output pin. Floated this pin in normal operation.

6.8 Power and Ground

Table 6-8 : Power and Ground Pin Descriptions

Pin Name	Type	LQFP Pin #	Cell	RESET # State	Description
IOV _{DD}	P	18, 48, 90, 104, 114	P	—	3.3V Power supply pins for I/O pads. It is recommended to place a 0.1µF bypass capacitor close to each of these pins.
IOV _{SS}	P	17, 49, 91, 103	P	—	Ground pins for I/O pads
COREV _{DD}	P	5, 27, 56, 73, 89, 101, 112	P	—	1.8V Power supply pins for core. It is recommended to place a 0.1µF bypass capacitor close to each of these pins.
COREV _{SS}	P	6, 28, 38, 55, 72, 88, 102, 111	P	—	Ground pins for core
PV _{DD}	P	34	P	—	1.8V Power supply pins for PLL. It is recommended to place a 0.1µF bypass capacitor close to each of these pins.
PV _{SS}	P	35	P	—	Ground pins for PLL

6.9 Summary of Configuration

These pins are used for configuration of the SSD1928 and must be connected directly to IOV_{DD} or IOV_{SS}. The state of AD_MODE, CNF[6, 4:0] is latched on the rising edge of RESET# or after the software reset function is activated (REG[A2h] bit 0). Changing state at any other time has no effect.

Table 6-9 : Summary of Configuration pins

SSD1928 Configuration Input	Power-On/Reset State	
	1 (Connected to IOV _{DD})	0 (Connected to IOV _{SS})
CNF[2:0], AD_MODE	Select host bus interface as follows:	
	AD_MODE	CNF2 CNF1 CNF0 Host Bus
	0	0 1 1 Generic#1
	0	1 0 0 Generic#2
	1	0 1 1 Indirect 8 bit 8080 (For Big Endian only)
1	1 0 0 Indirect 16 bit 8080	
	Note : The host bus interface is 18-bit only.	
CNF3	Configure GPIO pins as inputs at power-on	Configure GPIO pins as outputs at power-on
CNF4	Big Endian bus interface	Little Endian bus interface
CNF6	MCLK = PLL_CLK / 4	MCLK = PLL_CLK
	Note : Recommended to use CNF6 = 0 for Indirect addressing mode	

6.10 Host Bus Interface Pin Mapping

Table 6-10 : Host Bus Interface Pin Mapping

SSD1928 Pin Name	Generic #1	Generic #2	Indirect 8080
AB0	Connected to IOV _{SS}	A0	Connected to IOV _{SS}
AB[18:4, 2, 1]	A[18:4, 2, 1]		Connected to IOV _{SS}
AB[3]	A[3]		D/C#
DB[15:0]	D[15:0]		D[15:0]
CS#	External Decode		
M/R#	External Decode		Connected to IOV _{SS}
CLK12 (optional)	BUSCLK		
RD/WR#	RD1#	Connected to IOV _{DD}	Connected to V _{SS}
RD#	RD0#	RD#	RD#
WE0#	WE0#	WE#	WR#
WE1#	WE1#	BHE#	Connected to IOV _{SS}
RESET#	RESET#		

6.11 LCD Interface Pin Mapping

Table 6-11 : LCD Interface Pin Mapping

Pin Names	DUMB DRIVER					SMART DRIVER			
	Mono STN		CSTN		TFT	TFT	CSTN	OLED	TFT (Hitachi)
	4-bit	8-bit	4-bit	8-bit	Serial 8 bit	8/9-bit /3/4 wire			
LCD FRAME	FRAME					Drive 0	Drive 0	Drive 0	Drive 0
LCD LINE	LINE					Drive 0	Drive 0	Drive 0	Drive 0
LCD SHIFT	SHIFT					Drive 0	Drive 0	Drive 0	Drive 0
LCD DEN	MOD				DEN	Drive 0	Drive 0	Drive 0	Drive 0
LCD DATA0	Drive 0	D0	Drive 0	D0(B5) ¹	D0	D0			D0/SDA
LCD DATA1	Drive 0	D1	Drive 0	D1(R5) ¹	D1	D1			
LCD DATA2	Drive 0	D2	Drive 0	D2(G4) ¹	D2	D2			
LCD DATA3	Drive 0	D3	Drive 0	D3(B3) ¹	D3	D3			
LCD DATA4	D0	D4	D0(R2) ¹	D4(R3) ¹	D4	D4			
LCD DATA5	D1	D5	D1(B1) ¹	D5(G2) ¹	D5	D5			
LCD DATA6	D2	D6	D2(G1) ¹	D6(B1) ¹	D6	D6/SCK		D6	
LCD DATA7	D3	D7	D3(R1) ¹	D7(R1) ¹	D7	D7/SDA		D7	
LCD D/C#	Drive 0	Drive 0	Drive 0	Drive 0	Drive 0	D/C#			
LCD CS#	Drive 0	Drive 0	Drive 0	Drive 0	Drive 0	CS#			
LCD_WR#;LCD RD/WR#	Drive 0	Drive 0	Drive 0	Drive 0	Drive 0	WR#;R/W#			WR#;E;SCK
LCD_RD#;LCD E	Drive 0	Drive 0	Drive 0	Drive 0	Drive 0	RD#;E			RD#;R/W#

Note

(1) These pin mappings use signal names commonly used for each panel type, however signal names may differ between panel manufacturers. The values shown in brackets represent the color components as mapped to the corresponding LCD_DATA_{xx} signals at the first valid edge of LCD_SHIFT.

6.12 Data Bus Organization

There are two data bus architectures, little endian and big endian. Little endian means the bytes at lower addresses have lower significance. Big endian means the most significant byte has the lowest address.

Table 6-12 : Data Bus Organization

	D[15:8]	D[7:0]
Big endian	2N	2N + 1

Little endian	2N + 1	2N
----------------------	--------	----

Note

⁽¹⁾ N : Byte Address

Table 6-13 : Pin State Summary

MCU Mode (Endian)	A0	RD/WR#	RD#	WE1#	WE0#	Operation
Generic#1 (Big)	X	0	0	1	1	Word read
	X	0	1	1	1	High byte read 2N
	X	1	0	1	1	Low byte read 2N+1
	X	1	1	0	0	Word write
	X	1	1	0	1	High byte write 2N
	X	1	1	1	0	Low byte write 2N+1
Generic#1 (Little)	X	0	0	1	1	Word read
	X	0	1	1	1	High byte read 2N+1
	X	1	0	1	1	Low byte read 2N
	X	1	1	0	0	Word write
	X	1	1	0	1	High byte write 2N+1
	X	1	1	1	0	Low byte write 2N
Generic#2 (Big)	0	X	0	0	1	Word read
	0	X	0	1	1	High byte read 2N
	1	X	0	0	1	Low byte read 2N+1
	0	X	1	0	0	Word write
	0	X	1	1	0	High byte write 2N
	1	X	1	0	0	Low byte write 2N+1
Generic#2 (Little)	0	X	0	0	1	Word read
	1	X	0	0	1	High byte read 2N+1
	0	X	0	1	1	Low byte read 2N
	0	X	1	0	0	Word write
	1	X	1	0	0	High byte write 2N+1
	0	X	1	1	0	Low byte write 2N

7 FUNCTIONAL BLOCK DESCRIPTIONS

7.1 Phase Lock Loop (PLL)

The built-in PLL synthesizes the internal clock by an external 2MHz – 4MHz clock through the CLKI and CLKO. RC circuit should be connected if internal PLL is selected. The input of clock source can be either oscillator or crystal. If oscillator is used, the clock source is input directly to CLKI and leave CLKO floating. The target maximum output frequency of the PLL is 85MHz. If sync MCU interface, PLL should be disabled and use direct clock input to CLKI2.

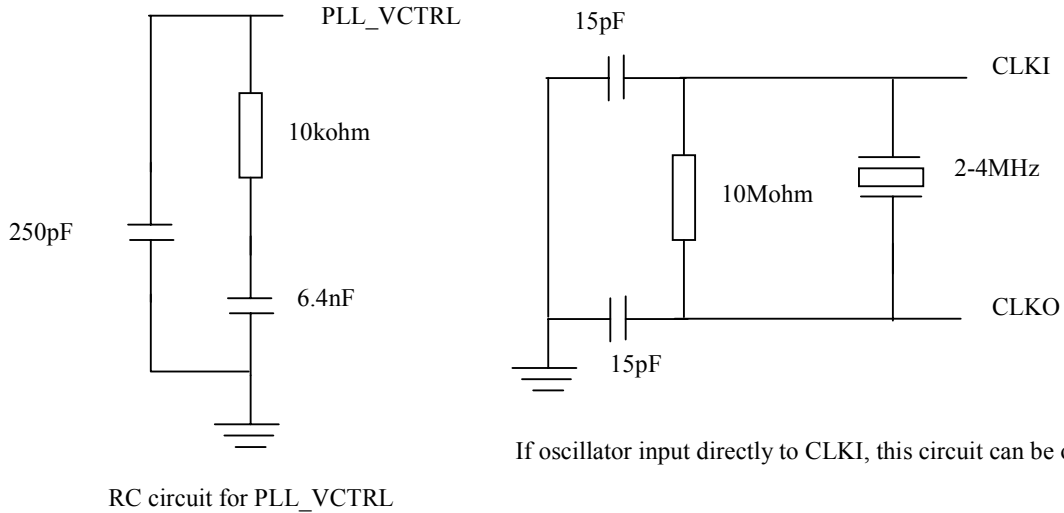

Figure 7-1 : Circuit for PLL enable

7.2 Embedded Memory

The 256kByte embedded memory can be access by the modules for different functions. For example, frame buffer, SD read/write buffer, internal buffer for JPEG encoding/decoding, encoded JPEG image output and so on.

7.3 MCU Interface

Responds to bus request for various kinds of MCU and translates to internal interface signals. SSD1928 can support direct and indirect addressing mode.

7.3.1 Generic #1 addressing Mode

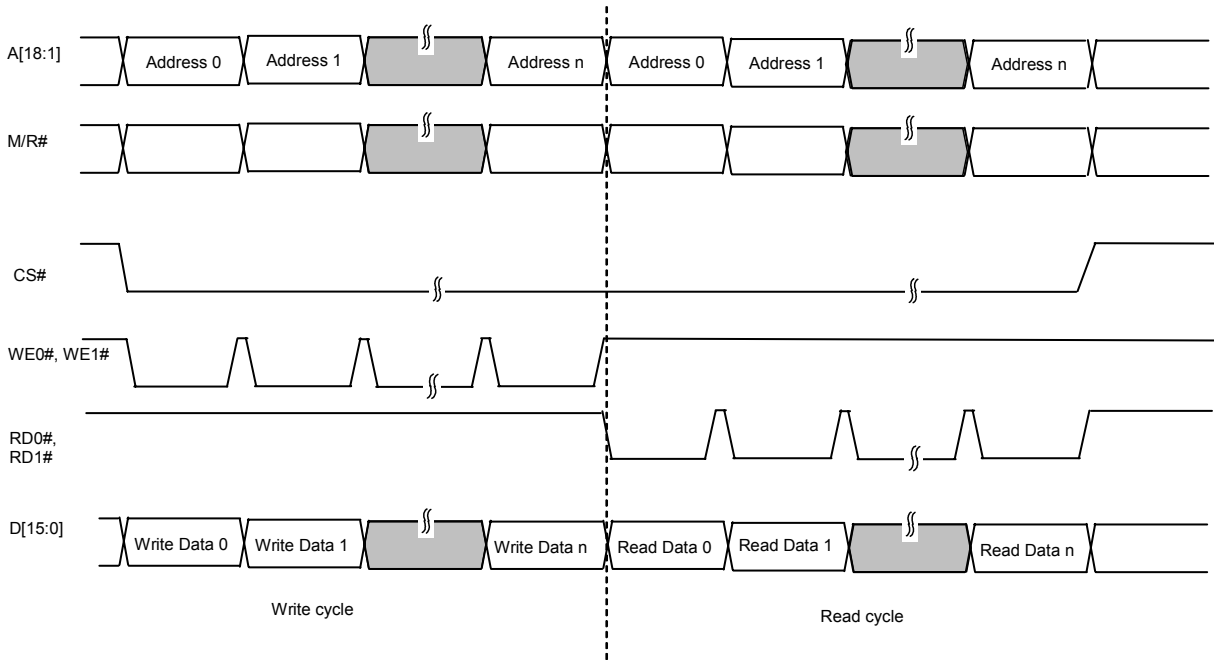

Note :

* 13 MCLK is needed for each cycle if WAIT# is not used for interface.

Figure 7-2 : Generic #1 Interface Timing

7.3.2 Generic #2 addressing Mode

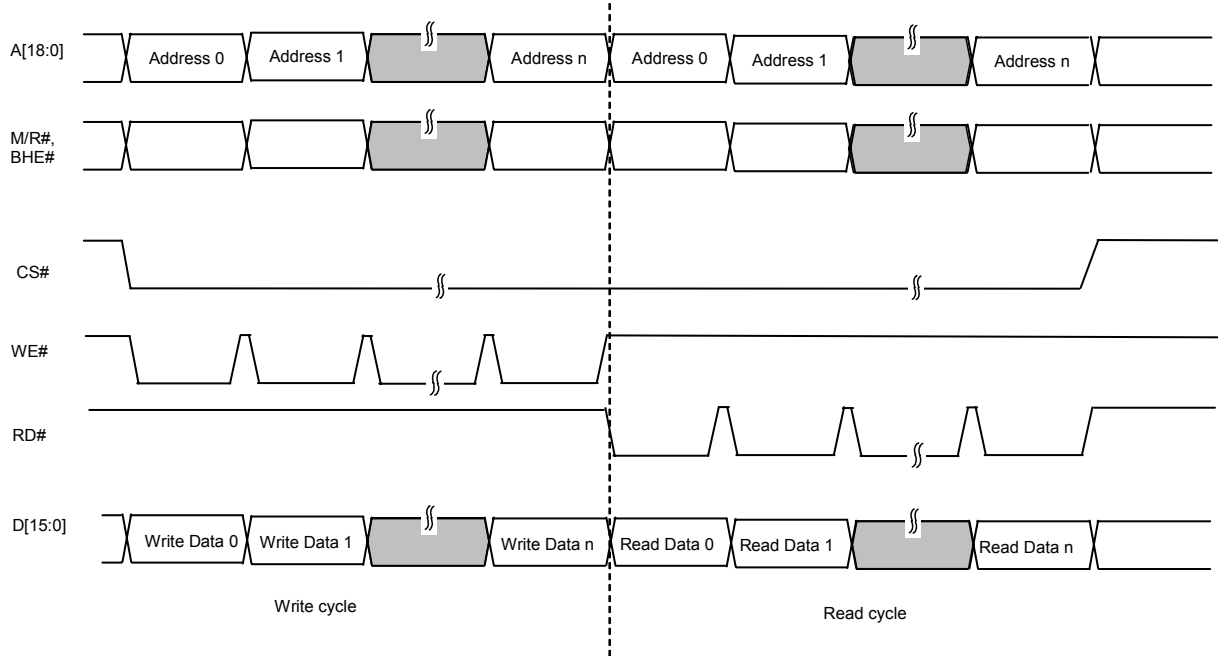

Note :
 * 13 MCLK is needed for each cycle if WAIT# is not used for interface.

Figure 7-3 : Generic #2 Interface Timing

7.3.3 8080 Indirect addressing Mode

8080 Indirect addressing mode consists of 16 or 8 bi-directional data pins (DB15:0), CS#, RD#, WR# and D/C#. CS# is the chip select; RD# is the read strobe; WR# is the write strobe; and D/C# is the data/command select. They can be used for either 8 bit (DB7:0) or 16 bit (DB15:0) bus protocol. CS# falling edge input serves as data read latch signal when RD# is low. D/C# controls whether reading the data or reading the command (i.e. status). CS# falling edge input serves as data write latch signal when WR# is low. D/C# controls whether writing the data or writing the command (i.e. address). In read operation, dummy invalid data read is required after start address.

The start address counter should be assigned before the data is written or read. The most significant bit of the start address is used to select the memory or register (M/R#). During the byte mode access, the address counter is automatically incremented by 1 byte after writing or reading the data. During the word mode access, the address counter is automatically incremented by 1 word after writing or reading the data. The address counter of memory will be returned to 0x00000 if counter = 0x3FFFF in byte mode or 0x3FFFE in word mode.

For 16 bit bus protocol, it can interface with byte or word mode access. The last byte of start address in 16-bit access will be used to select byte or word mode (MODE_SL). MODE_SL = 0x00 means byte access and MODE_SL = 0x01 means word access.

Read Burst Termination must be asserted for all JPEG related memory access. If the burst length is as small as 1, the read data stage may be reduced to a single dummy read.

Refer to section 12 for Pseudo-code examples.

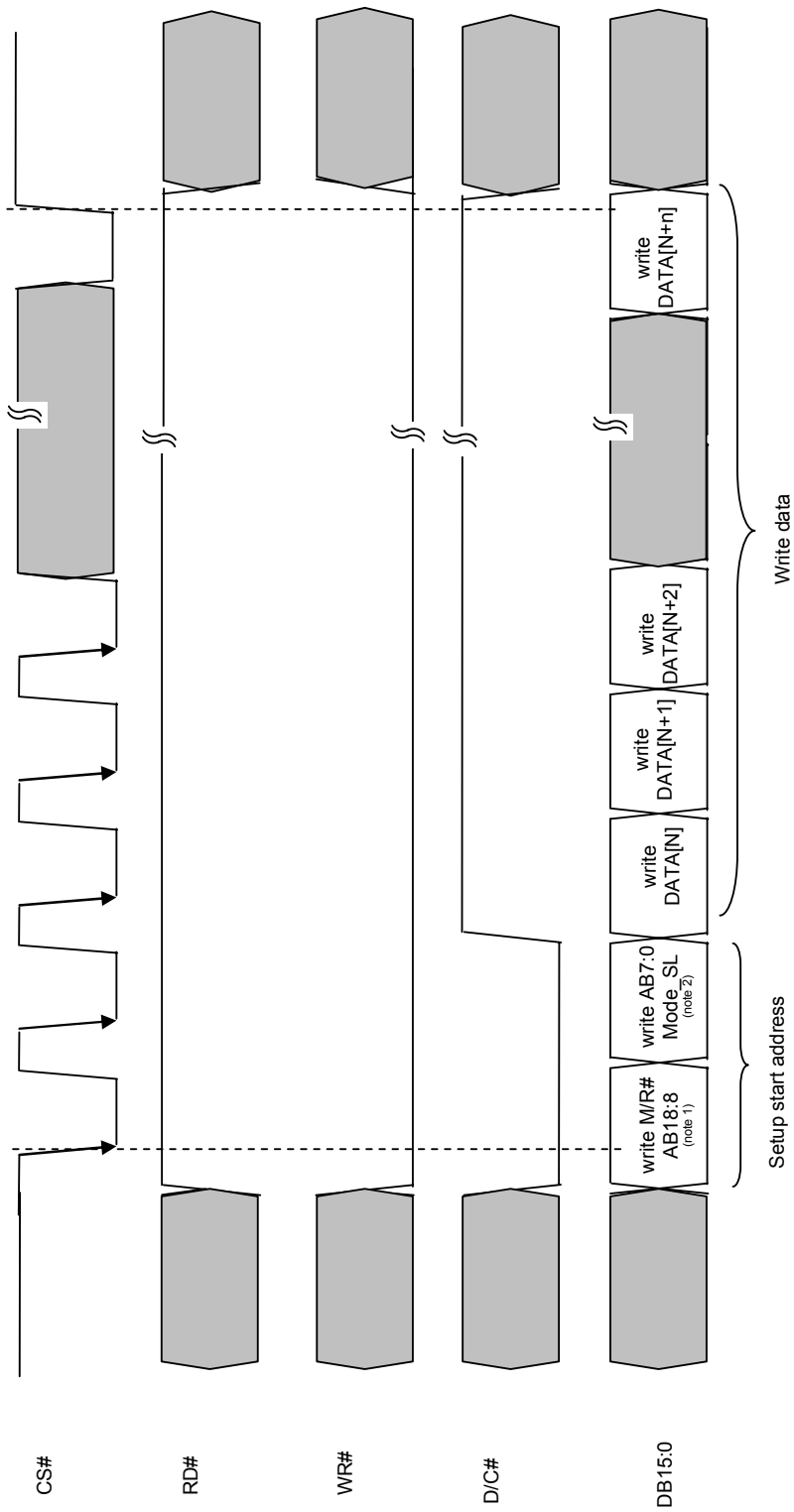

- Note :**
- 1 : Bit15 represent the M/R#, Bit15 = 1 means memory access, Bit15 = 0 means register access. Bit14:11 = 0.
 - 2 : Bit10:0 represent the the address AB18:8. Bit15:8 represent the address AB7:0 and Bit7:0 represent Mode_SL. Mode_SL to select byte or word access during 16 bit mode. 0x00 means Byte access, 0x01 means word access.
- * 7 MCLK is needed for each cycle if WAIT# is not used for interface.

Figure 7-4 : 8080 16 bit Interface Timing (write cycle)

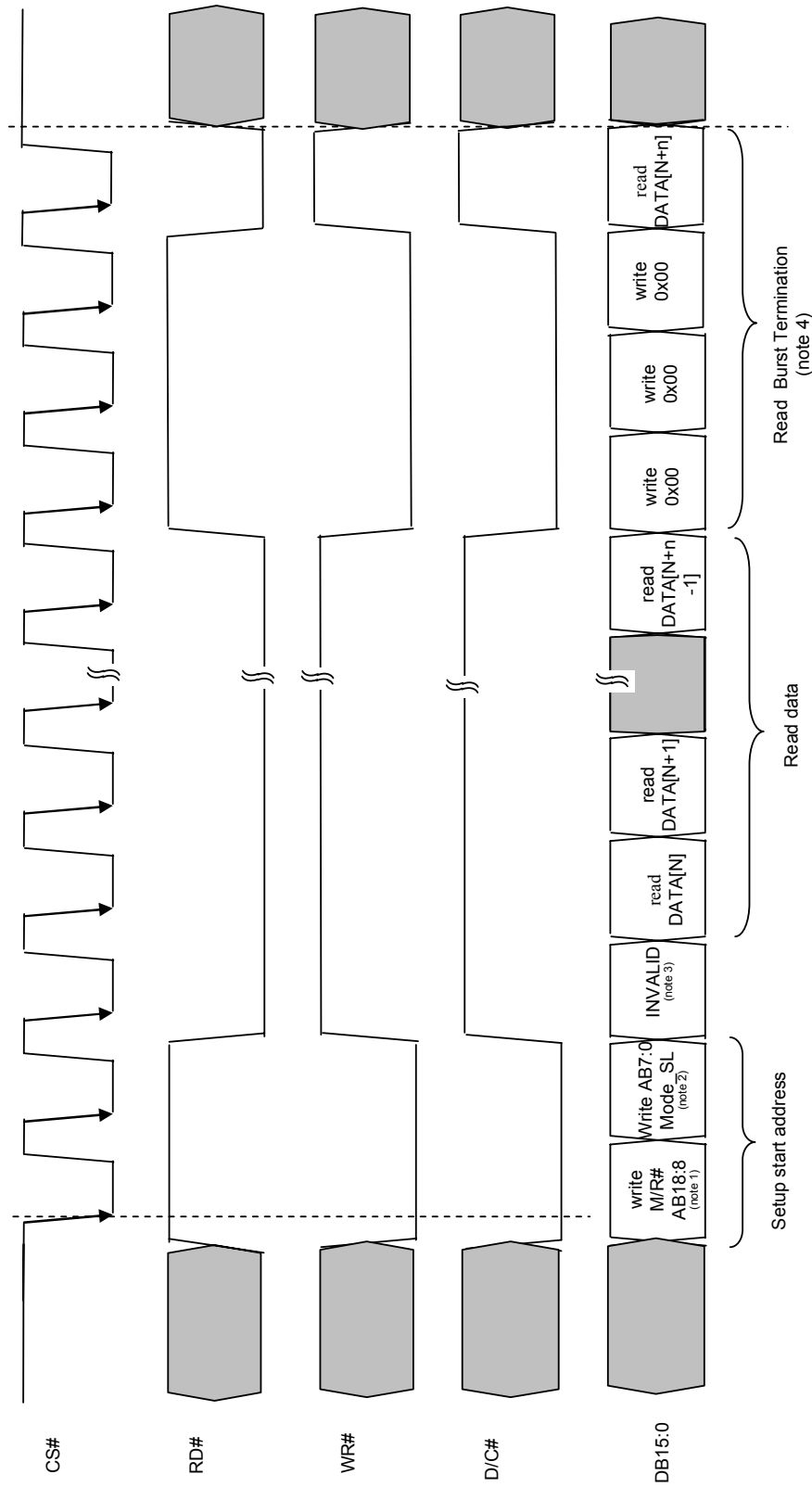

Note :

- 1 : Bit15 represent the M/R#, Bit15 = 1 means memory access, Bit15 = 0 means register access. Bit14:11 = 0.
- 2 : Bit10:0 represent the the address AB18:8.
- 3 : Bit15:8 represent the address AB7:0 and Bit7:0 represent Mode SL. Mode_SL to select byte or word access during 16 bit mode. 0x00 means Byte access, 0x01 means word access.
- 4 : Invalid dummy data cycle is needed after address is written. Read Burst Termination must be asserted for all JPEG related memory access.

* 7 MCLK is needed for each cycle if WAIT# is not used for interface.

Figure 7-5 : 8080 16 bit Interface Timing (read cycle)

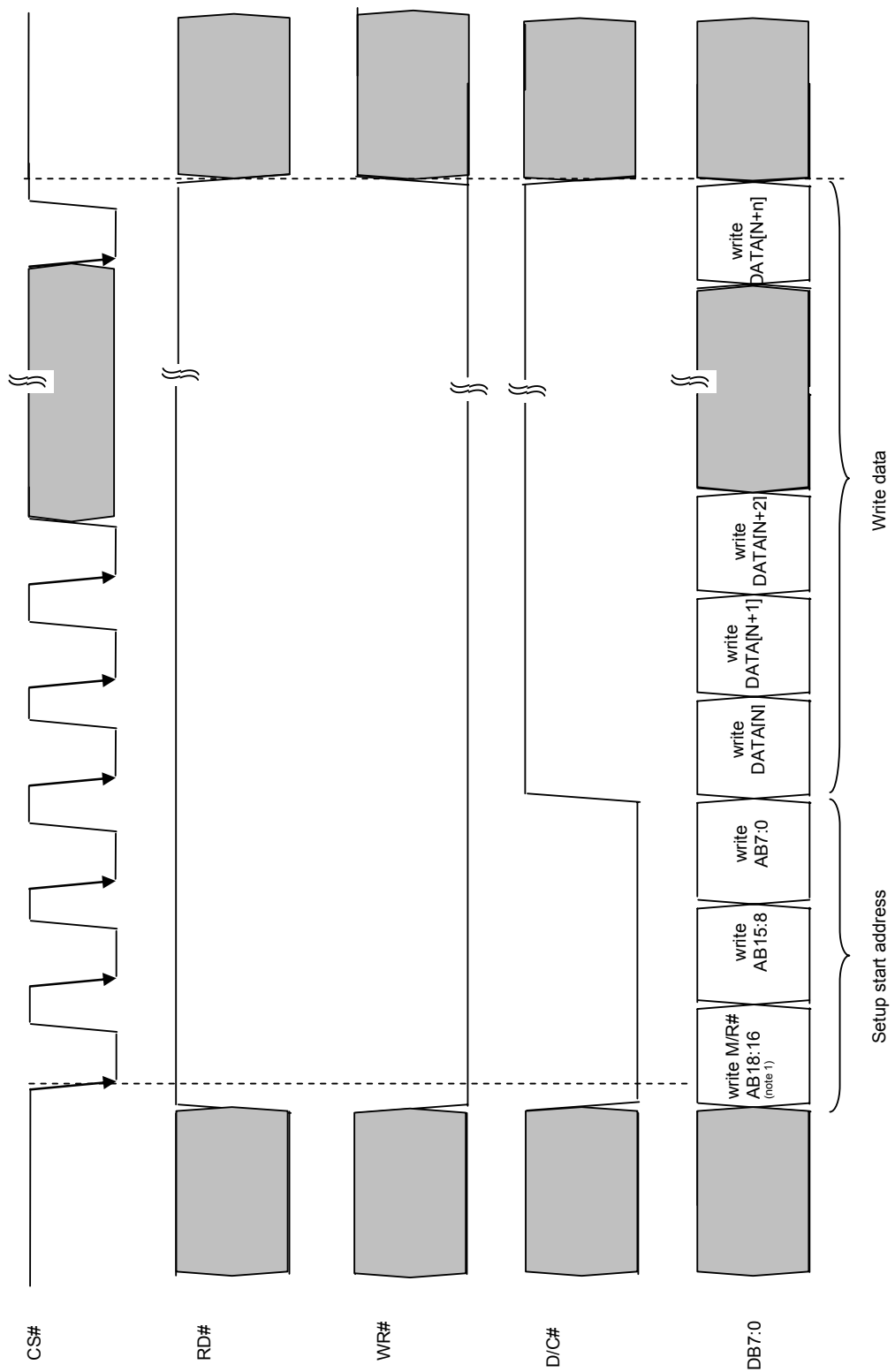
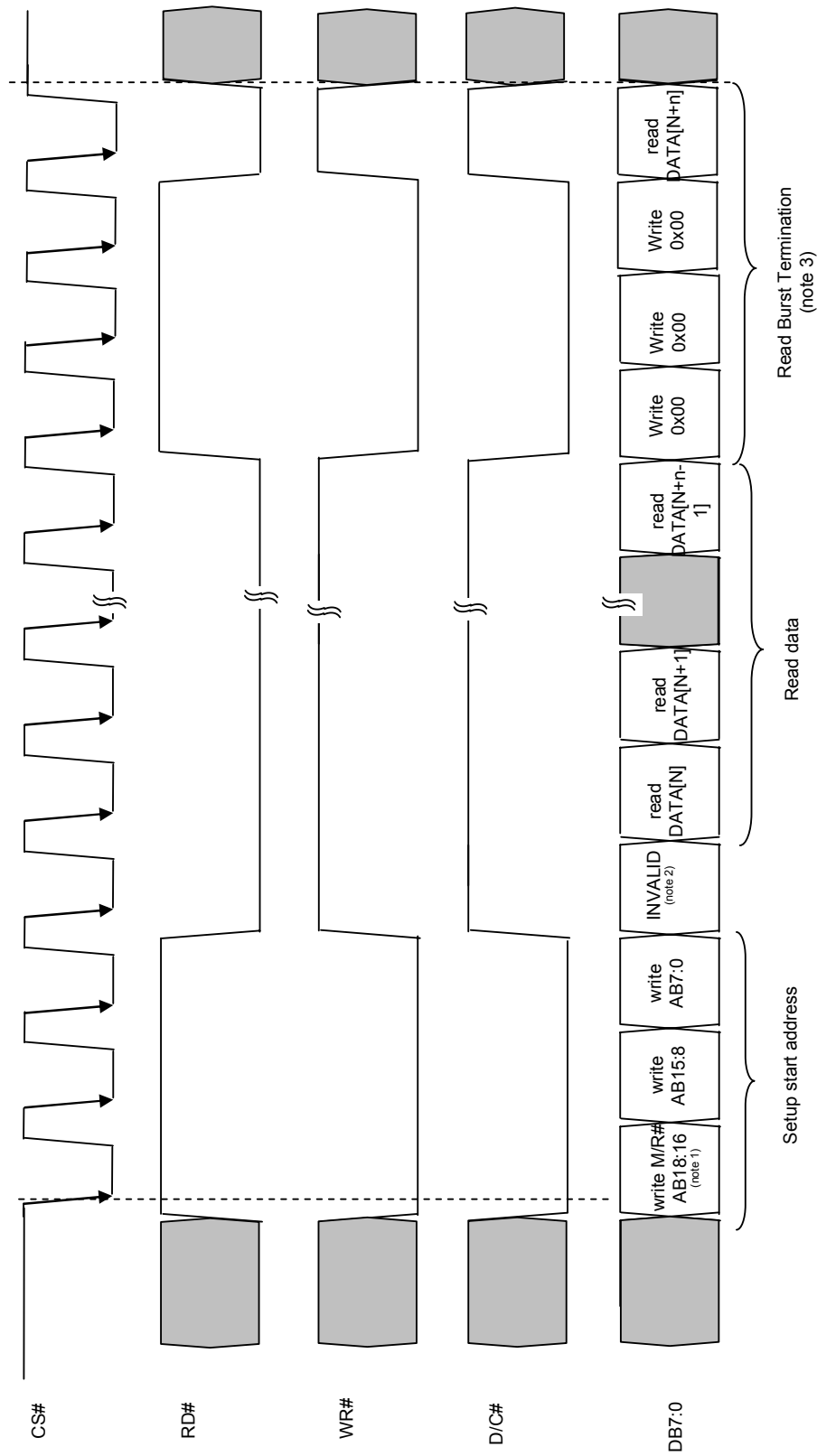

Figure 7-6 : 8080 8 bit Interface Timing (write cycle)

Note :
 1 : Bit7 represent the M/R#, Bit7 = 1 means memory access, Bit7 = 0 means register access.
 Bit6:3 = 0.
 Bit2:0 represent the the address AB18:16.

* 7 MCLK is needed for each cycle if WAIT# is not used for interface.



- Note :**
- 1 : Bit7 represent the M/R#, Bit7 = 1 means memory access, Bit7 = 0 means register access. Bit6:3 = 0.
 - 2 : Bit2:0 represent the the address AB18:16.
 - 3 : Invalid dummy read cycle is needed after address is written.
Read Burst Termination must be asserted for all JPEG related memory access.
- * 7 MCLK is needed for each cycle if WAIT# is not used for interface.

Figure 7-7 : 8080 8 bit Interface Timing (read cycle)

7.4 Registers

It stores all the register settings for different functional modules. Refer to Application Note for Register Table.

7.5 JPEG Encoder/Decoder

The JPEG codec can compress the image from CMOS camera to JPEG format and store to embedded memory. With help of MMC/SD card interface, the data can be stored in external MMC/SD card. Also, the codec can decompress the JPEG image from embedded memory to display⁽¹⁾. If the image stored in MMC/SD card is copied to embedded memory, the JPEG codec can decompress it to display also.

Note

⁽¹⁾ If the output memory address is the same as the overlay window, the decompressed image will be display immediately.

7.6 Image Capture Interface

The image capture interface can connect to a CMOS camera of resolution up to 1600 x 1200 (2.0 MegaPixel) or video source. The image is captured into the embedded memory. If the image capture is continuous, and the destination is the overlay window starting address, a preview window will be created. Since the CMOS camera resolution should be far higher than the display panel.

7.7 2D Engine

The 2D engine is designed on the basis of Microsoft Windows GDI. It support straight line drawing, rectangle drawing, rectangle color fill, rectangle pattern fill, BitBLT, color expansion, StretchBLT and alpha blending.

7.8 Display Interface

This is LCD interface for the main display. The maximum resolution of the LCD depends on the size of frame buffer located in the embedded memory. This display interface supports most panel type, including dump STN, CSTN, TFT. The smart STN, CSTN, TFT, OLED panel of parallel and serial interface are also supported.

7.9 MMC/SD/SDIO Interface

This interface act as a bridge between the MCU and the external memory card. This interface can also used as a bridge between the internal functional blocks such as JPEG encoder/decoder and external memory card. Since this interface also supports SDIO, the MCU can use this interface as an expansion slot.

7.10 General Purpose Input/Output (GPIO)

This is a collection of 5 GPIOs with can be used for LCD, keypad, LED backlight control and so on.

8 MAXIMUM RATINGS

Table 8-1: Absolute Maximum Ratings

Symbol	Parameter	Rating	Units
IOV _{DD}	Supply Voltage	V _{SS} - 0.3 to 4.0	V
V _{IN}	Input Voltage	V _{SS} - 0.3 to 5.0	V
V _{OUT}	Output Voltage	V _{SS} - 0.3 to IOV _{DD} + 0.5	V
T _{STG}	Storage Temperature	-65 to 150	°C
T _{SOL}	Solder Temperature/Time	260 for 10 sec. max at lead	°C

Maximum Ratings are those values beyond which damage to the device may occur. Functional operation should be restricted to the limits in the Electrical Characteristics tables or Pin Description section.

This device contains circuitry to protect the inputs against damage due to high static voltages or electric fields; however, it is advised that normal precautions to be taken to avoid application of any voltage higher than maximum rated voltages to this high impedance circuit. For proper operation it is recommended that V_{IN} and V_{OUT} be constrained to the range V_{SS} ≤ (V_{IN} or V_{OUT}) ≤ IOV_{DD}. Reliability of operation is enhanced if unused input are connected to an appropriate logic voltage level (e.g., either V_{SS} or IOV_{DD}). This device is not radiation protected.

Table 8-2 : Recommended Operating Conditions

Symbol	Parameter	Condition	Min	Typ	Max	Units
IOV _{DD}	Supply Voltage	V _{SS} = 0V	3.0	3.3	3.6	V
COREV _{DD}	Supply Voltage	V _{SS} = 0V	1.62	1.8	1.98	V
PV _{DD}	Supply Voltage	V _{SS} = 0V	1.62	1.8	1.98	V
V _{IN}	Input Voltage		V _{SS}		IOV _{DD}	V
T _{OPR}	Operating Temperature		-30	25	85	°C

9 DC CHARACTERISTICS

Table 9-1 : Electrical Characteristics for IOV_{DD} = 3.3V typical

Symbol	Parameter	Condition	Min	Typ	Max	Units
P _{STY}	Quiescent Power	Quiescent Conditions PLL_DIS = VSS		700		μW
I _{IZ}	Input Leakage Current		-1		1	μA
I _{OZ}	Output Leakage Current		-1		1	μA
V _{OH}	High Level Output Voltage	IOV _{DD} = min I _{OH} = -2mA (Type 1) -4mA (Type 2) -16mA (Type 3)	70% * IOV _{DD}			V
V _{OL}	Low Level Output Voltage	IOV _{DD} = min I _{OL} = 2mA (Type 1) 4mA (Type 2) 16mA (Type 3)			30% * IOV _{DD}	V
V _{IH}	High Level Input Voltage	LVTTL Level, IOV _{DD} = max	90% * IOV _{DD}			V
V _{IL}	Low Level Input Voltage	LVTTL Level, IOV _{DD} = min			10% * IOV _{DD}	V
V _{T+}	High Level Input Voltage	LVTTL Schmitt	1.1			V

10 AC CHARACTERISTICS

Conditions: $IOV_{DD} = 3.3V \pm 10\%$
 $T_A = -30^{\circ}C$ to $85^{\circ}C$
 T_{rise} and T_{fall} for all inputs must be < 5 ns (10% ~ 90%)
 $C_L = 50pF$ (Bus/CPU Interface)
 $C_L = 0pF$ (LCD Panel Interface)

10.1 Clock Timing

10.1.1 Input Clocks

Table 10-1 : Clock Input Requirements for CLKI

Symbol	Parameter	Min	Max	Units
F_{CLKI}	Input Clock Frequency (CLKI)	2	4	MHz
T_{CLKI}	Input Clock period (CLKI)	$1/f_{CLKI}$		ns

Table 10-2 : Oscillator Clock Input Requirements for CLKI2

Symbol	Parameter	Min	Max	Units
F_{CLKI2}	Input Clock Frequency (CLKI2)		85	MHz
T_{CLKI2}	Input Clock period (CLKI2)	$1/f_{CLKI2}$		ns

10.2 CPU Interface Timing

The following section are CPU interface AC Timing based on $IOV_{DD} = 3.3V$.

10.2.1 Generic #1 Interface Timing

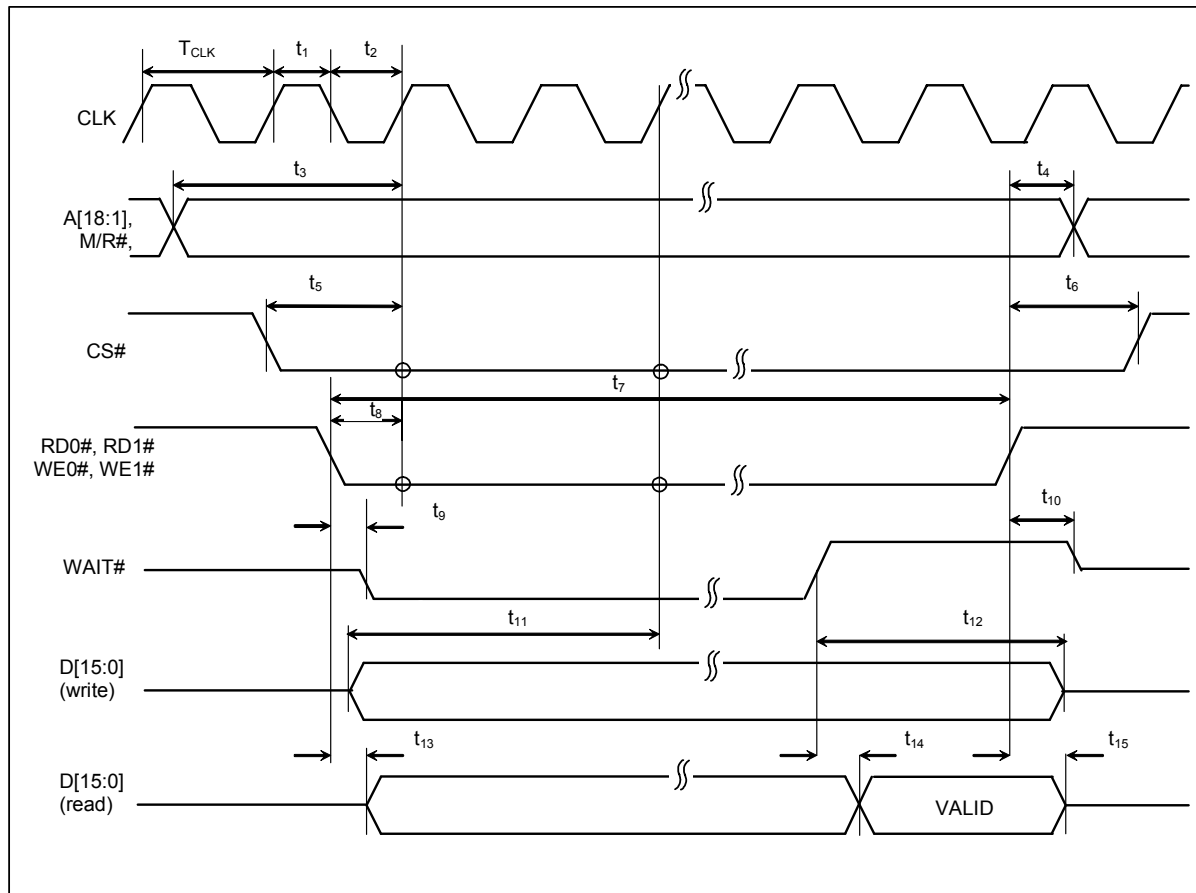

Figure 10-1 : Generic #1 Interface Timing

Table 10-3 : Generic #1 Interface Timing

Symbol	Parameter	Min	Max	Units
f_{CLK}	Bus Clock frequency		85	MHz
T_{CLK}	Bus Clock period	$1/f_{CLK}$		ns
t_1	Clock pulse width high	6		ns
t_2	Clock pulse width low	6		ns
t_3	A[18:1], M/R# setup to first CLK rising edge where CS# = 0 and either RD0#, RD1# = 0 or WE0#, WE1# = 0	1		ns
t_4	A[18:1], M/R# hold from either RD0#, RD1# or WE0#, WE1# rising edge	0		ns
t_5	CS# setup to CLK rising edge	1		ns
t_6	CS# hold from either RD0#, RD1# or WE0#, WE1# rising edge	1		ns
t_{7a}	RD0#, RD1#, WE0#, WE1# asserted for MCLK = PLL CLK		13	TCLK
t_{7b}	RD0#, RD1#, WE0#, WE1# asserted for MCLK = PLL CLK +2		18	TCLK
t_{7c}	RD0#, RD1#, WE0#, WE1# asserted for MCLK = PLL CLK +3		23	TCLK
t_{7d}	RD0#, RD1#, WE0#, WE1# asserted for MCLK = PLL CLK +4		28	TCLK
t_8	RD0#, RD1#, WE0#, WE1# setup to CLK rising edge	1		ns
t_9	Falling edge of either RD0#, RD1# or WE0#, WE1# to WAIT# driven low	3	15	ns
t_{10}	Rising edge of either RD0#, RD1# or WE0#, WE1# to WAIT# high impedance	3	13	ns
t_{11}	D[15:0] setup to third CLK rising edge where CS# = 0 and WE0#, WE1# = 0 (write cycle)(see note 1)	0		ns
t_{12}	D[15:0] hold from WAIT# rising edge (write cycle)	0		ns
t_{13}	RD0#, RD1# falling edge to D[15:0] driven (read cycle)	3	14	ns
t_{14}	WAIT# rising edge to D[15:0] valid (read cycle)		2	ns
t_{15}	RD0#, RD1# rising edge to D[15:0] high impedance (read cycle)	3	11	ns

1. t_{11} is the delay from when data is placed on the bus until the data is latched into the write buffer.

10.2.2 Generic #2 Interface Timing (e.g. ISA)

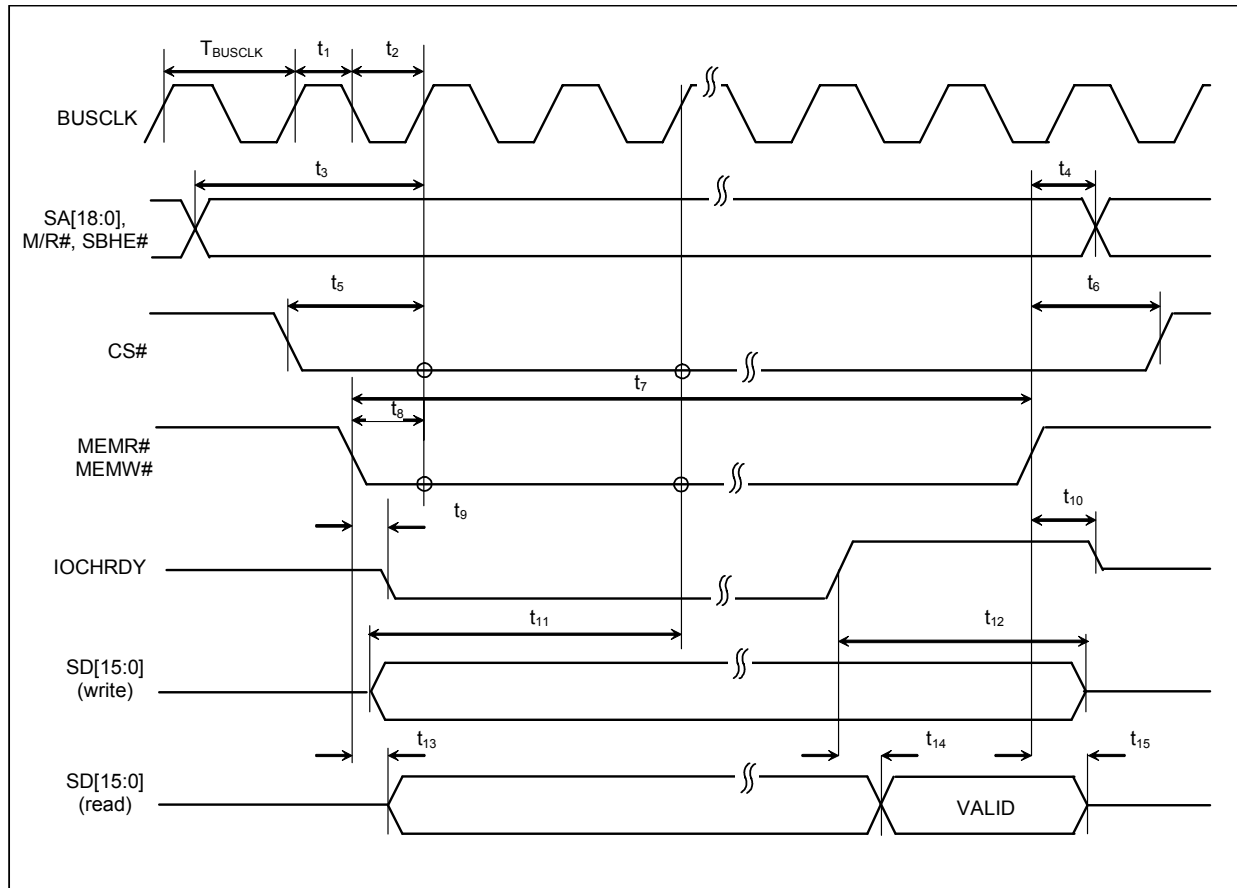

Figure 10-2 : Generic #2 Interface Timing

Table 10-4 : Generic #2 Interface Timing

Symbol	Parameter	Min	Max	Units
f_{BUSCLK}	Bus Clock frequency		85	MHz
T_{BUSCLK}	Bus Clock period	$1/f_{\text{BUSCLK}}$		ns
t_1	Clock pulse width high	6		ns
t_2	Clock pulse width low	6		ns
t_3	SA[18:0], M/R#, SBHE# setup to first BUSCLK rising edge where CS# = 0 and either MEMR# = 0 or MEMW# = 0	1		ns
t_4	SA[18:0], M/R#, SBHE# hold from either MEMR# or MEMW# rising edge	0		ns
t_5	CS# setup to BUSCLK rising edge	1		ns
t_6	CS# hold from either MEMR# or MEMW# rising edge	0		ns
t_{7a}	MEMR# or MEMW# asserted for MCLK = PLL_CLK		13	T_{BUSCLK}
t_{7b}	MEMR# or MEMW# asserted for MCLK = PLL_CLK +2		18	T_{BUSCLK}
t_{7c}	MEMR# or MEMW# asserted for MCLK = PLL_CLK +3		23	T_{BUSCLK}
t_{7d}	MEMR# or MEMW# asserted for MCLK = PLL_CLK +4		28	T_{BUSCLK}
t_8	MEMR# or MEMW# setup to BUSCLK rising edge	1		ns
t_9	Falling edge of either MEMR# or MEMW# to IOCHRDY driven low	3	15	ns
t_{10}	Rising edge of either MEMR# or MEMW# to IOCHRDY high impedance	3	13	ns
t_{11}	SD[15:0] setup to third BUSCLK rising edge where CS# = 0 and MEMW#=0 (write cycle)(see note1)	0		ns
t_{12}	SD[15:0] hold from IOCHRDY rising edge (write cycle)	0		ns
t_{13}	MEMR# falling edge to SD[15:0] driven (read cycle)	3	13	ns
t_{14}	IOCHRDY rising edge to SD[15:0] valid (read cycle)		2	ns
t_{15}	Rising edge of MEMR# to SD[15:0] high impedance (read cycle)	3	12	ns

1. t_{11} is the delay from when data is placed on the bus until the data is latched into the write buffer.

10.2.3 8080 Indirect Interface Timing

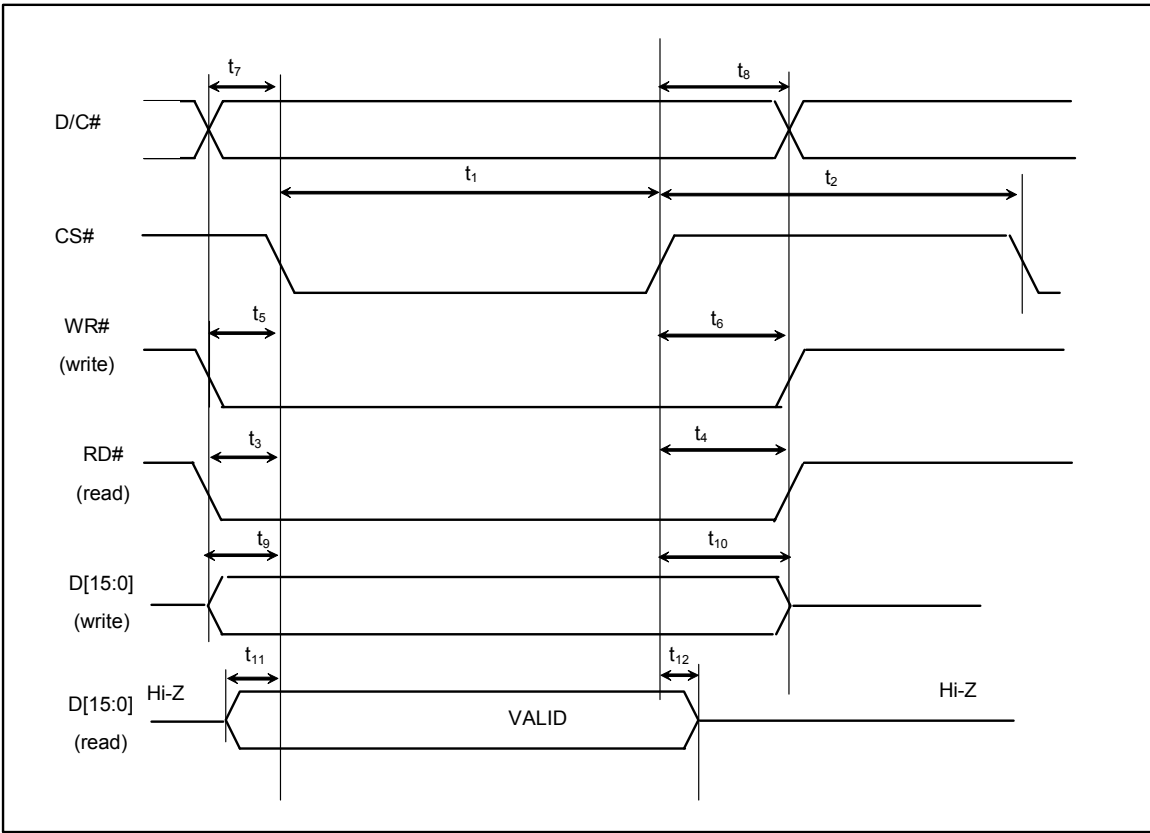

Figure 10-3 : 8080 Interface Timing

Table 10-5 : 8080 Interface Timing

Symbol	Parameter	Min	Max	Units
t_1	CS# pulse width low	82		ns
t_2	CS# pulse width high	82		ns
t_3	RD# setup	18		ns
t_4	RD# hold	0		ns
t_5	WR# setup	18		ns
t_6	WR# hold	0		ns
t_7	D/C# setup	18		ns
t_8	D/C# hold	0		ns
t_9	D[15:0] setup for write	18		ns
t_{10}	D[15:0] hold for write	0		ns
t_{11}	D[15:0] delay for read	55		ns
t_{12}	D[15:0] hold for read	0		ns

Note : Above timing is based on MCLK = 85MHz

11 APPLICATION EXAMPLES

11.1 Application Diagram

Figure 11-1 : Typical System Diagram (Generic #1 Bus)

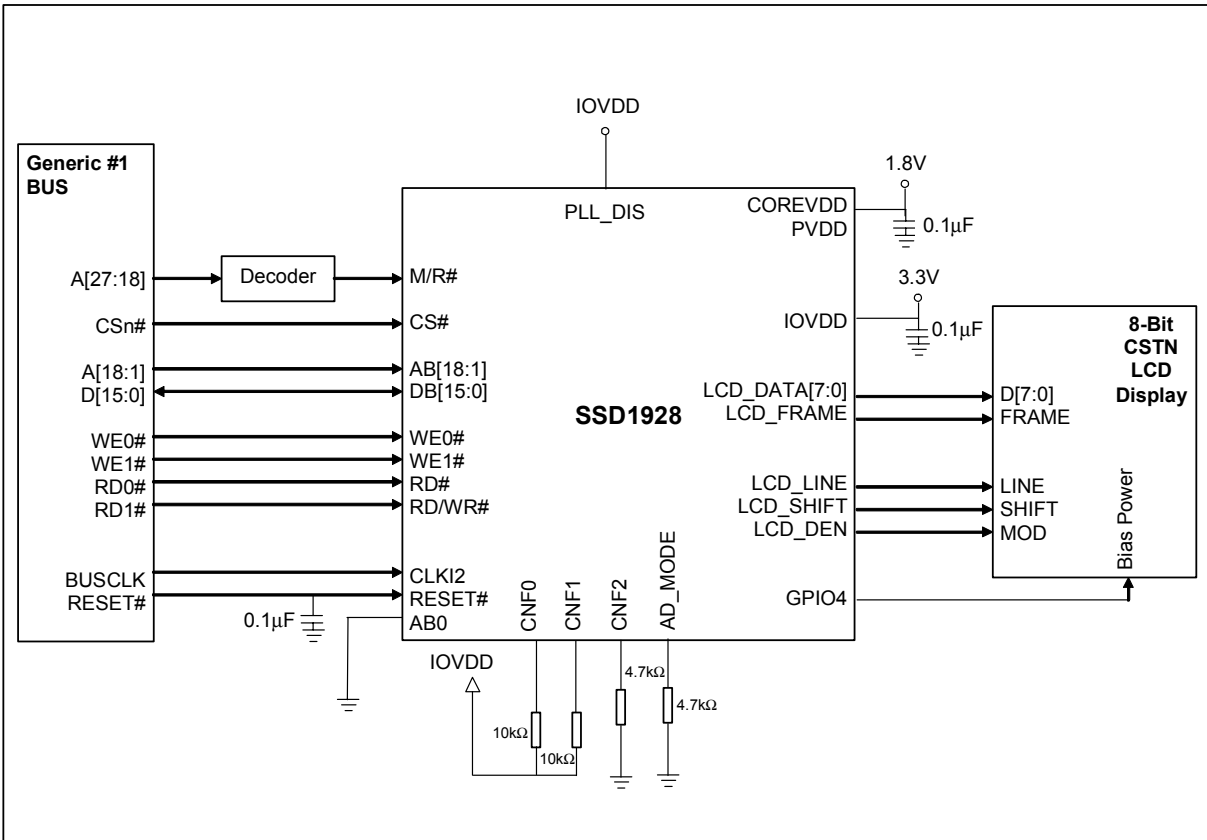

Figure 11-2 : Typical System Diagram (Generic #2 Bus)

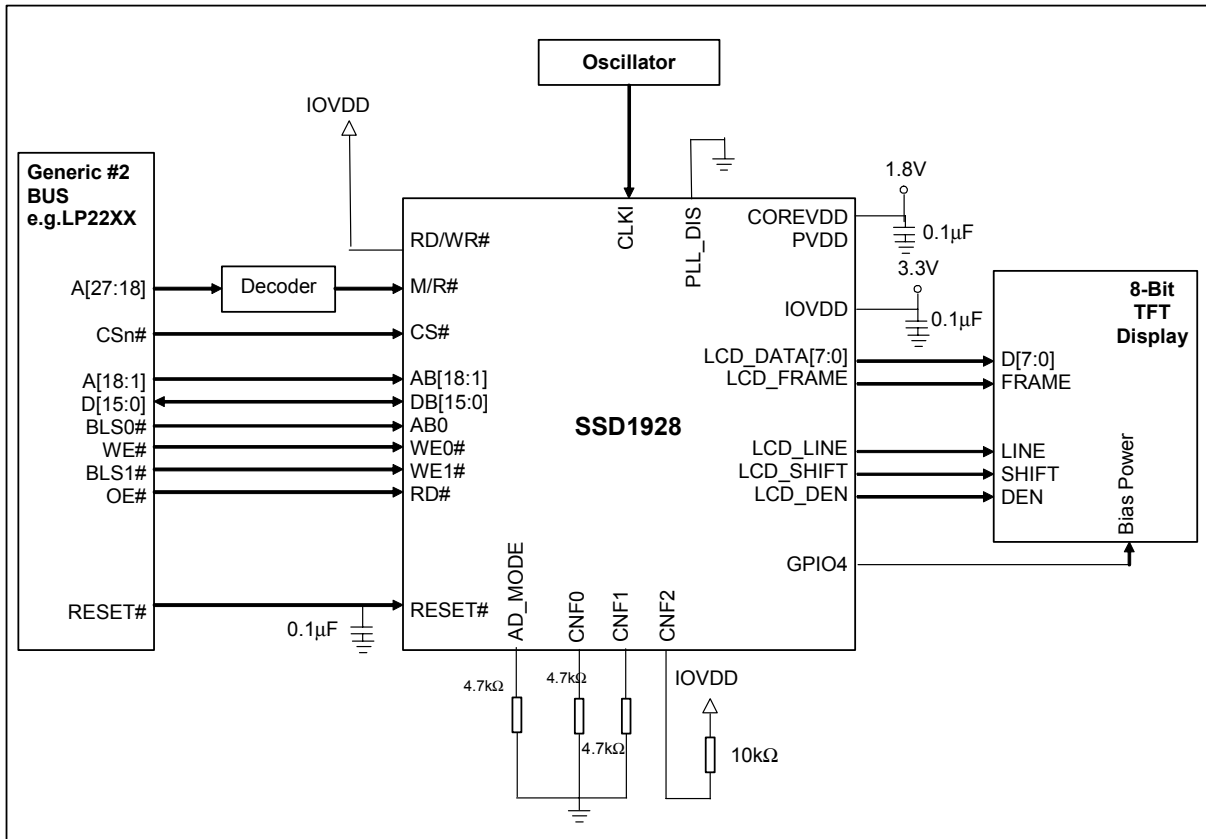
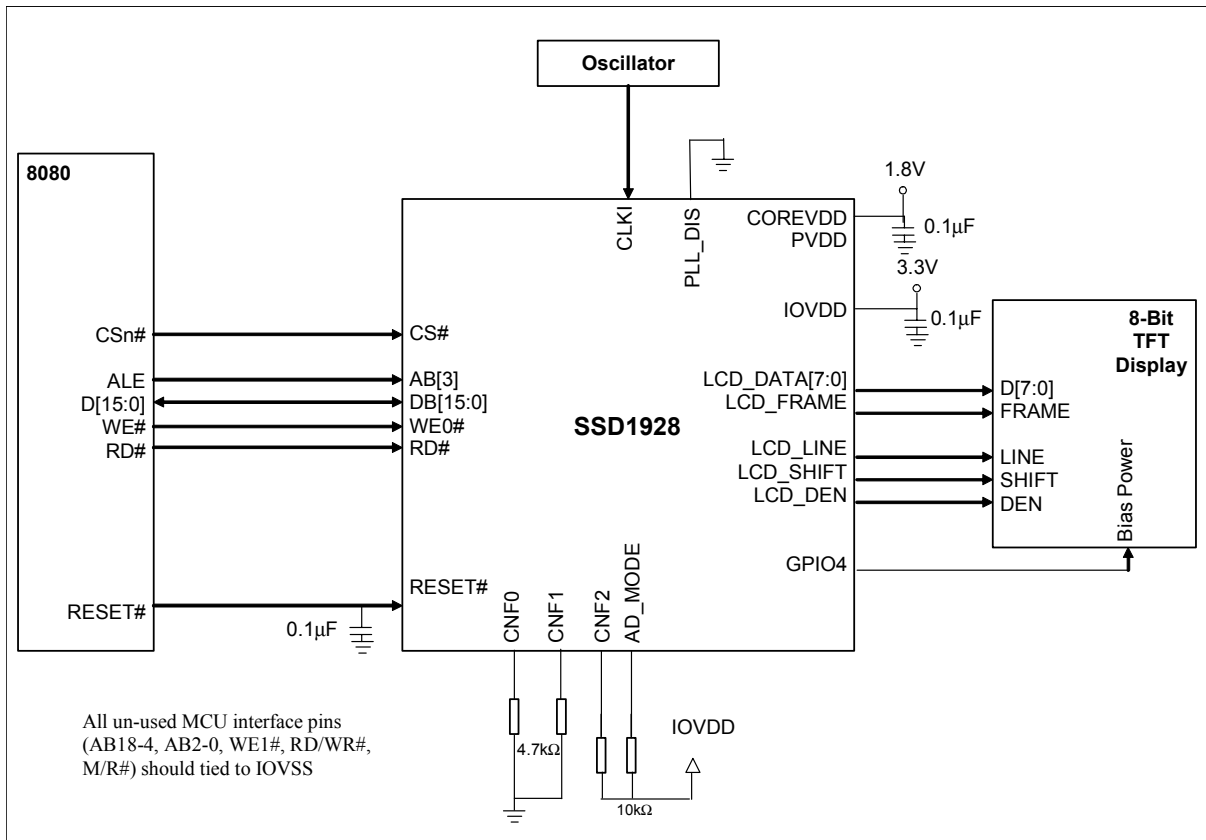

Figure 11-3 : Typical System Diagram (Indirect 8080 16 bit Bus)



12 Pseudo-code Examples for Indirect address mode

12.1 8080 Indirect address mode

For example, PORTA is used for control signals and PORTB is used for data signals.

PORTA[3:0] are the control signals

PORTA[7]	PORTA[6]	PORTA[5]	PORTA[4]	PORTA[3]	PORTA[2]	PORTA[1]	PORTA[0]
X	X	X	X	CS#	RD#	WR#	D/C#

X : Don't care

PORTB[15:0] are the data signals for 16 bit mode

PORTB[7:0] are the data signals for 8 bit mode

read_command (cmd)		
write PORTA, 0x0A		[CS#=1, RD#=0, WR#=1, D/C#=0]
write PORTA, 0x02		[CS#=0, RD#=0, WR#=1, D/C#=0]
read PORTB, cmd		
write PORTA, 0x0E		[CS#=1, RD#=1, WR#=1, D/C#=0]
read_data (data)		
write PORTA, 0x0B		[CS#=1, RD#=0, WR#=1, D/C#=1]
write PORTA, 0x03		[CS#=0, RD#=0, WR#=1, D/C#=1]
read PORTB, data		
write PORTA, 0x0F		[CS#=1, RD#=1, WR#=1, D/C#=1]
write_command (cmd)		
write PORTB, cmd		
write PORTA, 0x0C		[CS#=1, RD#=1, WR#=0, D/C#=0]
write PORTA, 0x04		[CS#=0, RD#=1, WR#=0, D/C#=0]
write PORTA, 0x0E		[CS#=1, RD#=1, WR#=1, D/C#=0]
write_data (data)		
write PORTB, data		
write PORTA, 0x0D		[CS#=1, RD#=1, WR#=0, D/C#=1]
write PORTA, 0x05		[CS#=0, RD#=1, WR#=0, D/C#=1]
write PORTA, 0x0F		[CS#=1, RD#=1, WR#=1, D/C#=1]

Example 1 : Register Access with 16 bit indirect address mode (Big Endian, CNF4=1) with Word Mode

(Write **Register** REG[0x010h]=0x11, REG[0x011h]=0x22, REG[0x012h]=0x33, REG[0x013h]=0x04 and read back the contents)

Step 1: Set the start address to 0x00010 and write DATA0
write_command 0x0000 [M/R#=0 => Register]
write_command 0x1001 [start address = 0x00010, MODE_SL=0x01 => Word]
write_data 0x1122 [write word 0x1122 to REG[0x010]]

Step 2 : Write DATA1
write_data 0x3304 [write word 0x3304 to REG[0x012]]

Step 3 : Set the start Address to 0x00010 and dummy read
write_command 0x0000 [M/R#=0 => Register]
write_command 0x1001 [start address = 0x00010,MODE_SL=0x01 => Word]
read_data DUMMY [first read cycle is dummy]

Step 4 : Read Back the Data [Total = 4 bytes]
read_data DATA0 [read back value is 0x1122 => REG[0x010]=0x1122]
read_data DATA1 [read back value is 0x3304 => REG[0x012]=0x3304]

Example 2 : Register Access with 16 bit indirect address mode (Big Endian, CNF4=1) with Byte Mode

(Write **Register** REG[0x010h]=0x11, REG[0x011h]=0x22, REG[0x012h]=0x33, REG[0x013h]=0x04 and read back the contents)

Step 1: Set the start address to 0x00010 and write DATA0
write_command 0x0000 [M/R#=0 => Register]
write_command 0x1000 [start address = 0x00010, MODE_SL=0x00 => Byte]
write_data 0x1122 [write word 0x11 to REG[0x010]]

Step 2 : Write the DATA1-3
write_data 0x3344 [write word 0x44 to REG[0x011]]
write_data 0xAABB [write word 0xAA to REG[0x012]]
write_data 0xCC07 [write word 0x07 to REG[0x013]]

Step 3 : Set the start Address to 0x00010 and dummy read
write_command 0x0000 [M/R#=0 => Register]
write_command 0x1000 [start address = 0x00010,MODE_SL=0x00 => Byte]
read_data DUMMY [first read cycle is dummy]

Step 4 : Read Back the Data [Total = 4 bytes]
read_data DATA0 [read back value is 0x1144 => REG[0x010]=0x11]
read_data DATA1 [read back value is 0x1144 => REG[0x011]=0x44]
read_data DATA2 [read back value is 0xAA07 => REG[0x012]=0xAA]
read_data DATA3 [read back value is 0xAA07 => REG[0x013]=0x07]

Example 3 : Memory Access with 16 bit indirect address mode (Big Endian, CNF4=1) with Word Mode

(Write **Memory** AB[0x00910h]=0x11, AB[0x00911h]=0x22, AB[0x00912h]=0x33, AB[0x00913h]=0x44 and read back the contents)

```

Step 1: Set the start address to 0x00910 and write DATA0
    write_command 0x8009      [M/R#=1 => Memory]
    write_command 0x1001      [start address = 0x00910, MODE_SL=0x01 => Word]
    write_data 0x1122        [write word 0x1122 to 0x00910]
Step 2 : Write the DATA1
    write_data 0x3344        [write word 0x3344 to 0x00912]
Step 3 : Set the start Address to 0x00910 and dummy read
    write_command 0x8009      [M/R#=1 => Memory]
    write_command 0x1001      [start address = 0x00910,MODE_SL=0x01 => Word]
    read_data DUMMY          [first read cycle is dummy]
Step 4 : Read Back the Data [Total = 4 bytes]
    read_data DATA0         [read back value is 0x1122 => AB[0x00910]=0x1122]
    read_data DATA1         [read back value is 0x3344 => AB[0x00912]=0x3344]

```

Example 4 : Memory Access with 16 bit indirect address mode (Big Endian, CNF4=1) with Byte Mode

(Write **Memory** AB[0x00910h]=0x11, AB[0x00911h]=0x22, AB[0x00912h]=0x33, AB[0x00913h]=0x44 and read back the contents)

```

Step 1: Set the start address to 0x00910 and write DATA0
    write_command 0x8009      [M/R#=1 => Memory]
    write_command 0x1000      [start address = 0x00910, MODE_SL=0x00 => Byte]
    write_data 0x1122        [write word 0x11 to AB[0x00910]]
Step 2 : Write the DATA1-3
    write_data 0x3344        [write word 0x44 to AB[0x00911]]
    write_data 0xAABB        [write word 0xAA to AB[0x00912]]
    write_data 0xCCDD        [write word 0xDD to AB[0x00913]]
Step 3 : Set the start Address to 0x00910 and dummy read
    write_command 0x8009      [M/R#=1 => Memory]
    write_command 0x1000      [start address = 0x00910,MODE_SL=0x00 => Byte]
    read_data DUMMY          [first read cycle is dummy]
Step 4 : Read Back the Data [Total = 4 bytes]
    read_data DATA0         [read back value is 0x1144 => AB[0x00910]=0x11]
    read_data DATA1         [read back value is 0x1144 => AB[0x00911]=0x44]
    read_data DATA2         [read back value is 0xAADD => AB[0x00912]=0xAA]
    read_data DATA3         [read back value is 0xAADD => AB[0x00913]=0xDD]

```

Example 5 : Register Access with 8 bit indirect address mode (Big Endian, CNF4=1)

(Write **Register** REG[0x010h]=0x11, REG[0x011h]=0x22, REG[0x012h]=0x33, REG[0x013h]=0x04 and read back the contents)

Step 1: Set the start address to 0x00010 and write DATA0
write_command 0x00 [M/R#=0 => Register]
write_command 0x00
write_command 0x10 [start address = 0x00010]
write_data 0x11 [write word 0x11 to REG[0x010]]

Step 2 : Write the DATA1-3
write_data 0x22 [write word 0x22 to REG[0x011]]
write_data 0x33 [write word 0x33 to REG[0x012]]
write_data 0x04 [write word 0x04 to REG[0x013]]

Step 3 : Set the start Address to 0x00010 and dummy read
write_command 0x00 [M/R#=0 => Register]
write_command 0x00
write_command 0x10 [start address = 0x00010]
read_data DUMMY [first read cycle is dummy]

Step 4 : Read Back the Data [Total = 4 bytes]
read_data DATA0 [read back value is 0x11 => REG[0x010]=0x11]
read_data DATA1 [read back value is 0x22 => REG[0x011]=0x22]
read_data DATA2 [read back value is 0x33 => REG[0x012]=0x33]
read_data DATA3 [read back value is 0x04 => REG[0x013]=0x04]

Example 6 : Memory Access with 8 bit indirect address mode (Big Endian, CNF4=1)

(Write **Memory** AB[0x00910h]=0x11, AB[0x00911h]=0x22, AB[0x00912h]=0x33, AB[0x00913h]=0x44 and read back the contents)

```
Step 1: Set the start address to 0x00910 and write DATA0
      write_command 0x80      [M/R#=1 => Memory]
      write_command 0x09
      write_command 0x10      [start address = 0x00910]
      write_data 0x11        [write word 0x11 to AB[0x00910]]
Step 2 : Write the DATA1-3
      write_data 0x22        [write word 0x22 to AB[0x00911]]
      write_data 0x33        [write word 0x33 to AB[0x00912]]
      write_data 0x44        [write word 0x44 to AB[0x00913]]
Step 3 : Set the start Address to 0x00910 and dummy read
      write_command 0x80      [M/R#=1 => Memory]
      write_command 0x09
      write_command 0x10      [start address = 0x00910]
      read_data DUMMY        [first read cycle is dummy]
Step 4 : Read Back the Data [Total = 4 bytes]
      read_data DATA0       [read back value is 0x11 => AB[0x00910]=0x11]
      read_data DATA1       [read back value is 0x22 => AB[0x00911]=0x22]
      read_data DATA2       [read back value is 0x33 => AB[0x00912]=0x33]
      read_data DATA3       [read back value is 0x44 => AB[0x00913]=0x44]
```

13 PACKAGE INFORMATION

13.1 Package Mechanical Drawing for 128 pins LQFP

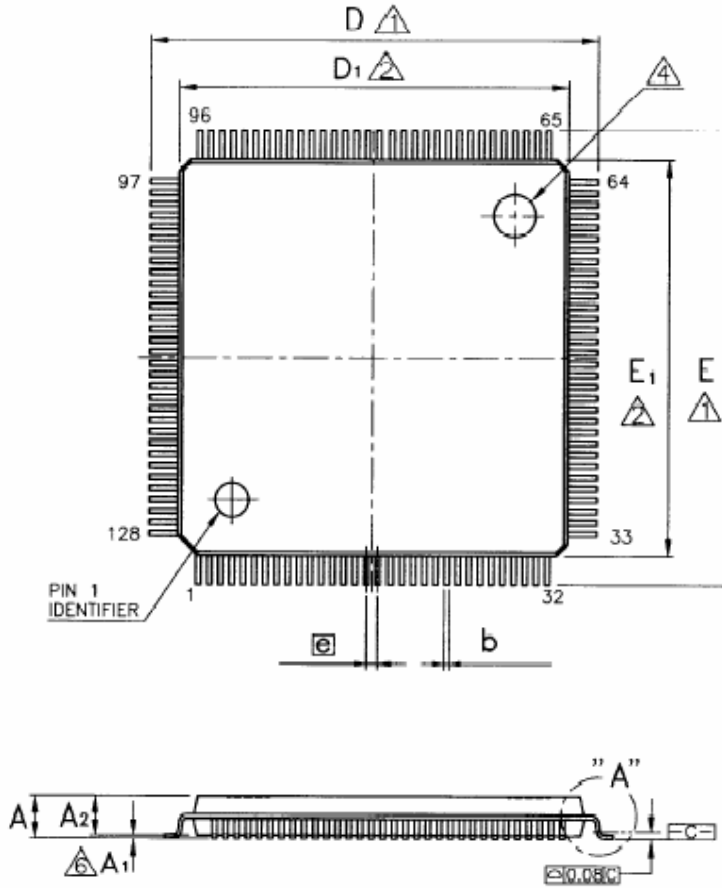

Symbol	Dimension in mm		
	Min	Nom	Max
A			1.60
A1	0.05		
A2		1.40	
D		16.00	
D1		14.00	
E		16.00	
E1		14.00	
e	0.40 BSC		
b		0.18	

Solomon Systech reserves the right to make changes without notice to any products herein. Solomon Systech makes no warranty, representation or guarantee regarding the suitability of its products for any particular purpose, nor does Solomon Systech assume any liability arising out of the application or use of any product or circuit, and specifically disclaims any, and all, liability, including without limitation consequential or incidental damages. "Typical" parameters can and do vary in different applications. All operating parameters, including "Typical" must be validated for each customer application by the customer's technical experts. Solomon Systech does not convey any license under its patent rights nor the rights of others. Solomon Systech products are not designed, intended, or authorized for use as components in systems intended for surgical implant into the body, or other applications intended to support or sustain life, or for any other application in which the failure of the Solomon Systech product could create a situation where personal injury or death may occur. Should Buyer purchase or use Solomon Systech products for any such unintended or unauthorized application, Buyer shall indemnify and hold Solomon Systech and its offices, employees, subsidiaries, affiliates, and distributors harmless against all claims, costs, damages, and expenses, and reasonable attorney fees arising out of, directly or indirectly, any claim of personal injury or death associated with such unintended or unauthorized use, even if such claim alleges that Solomon Systech was negligent regarding the design or manufacture of the part.

<http://www.solomon-systech.com>