

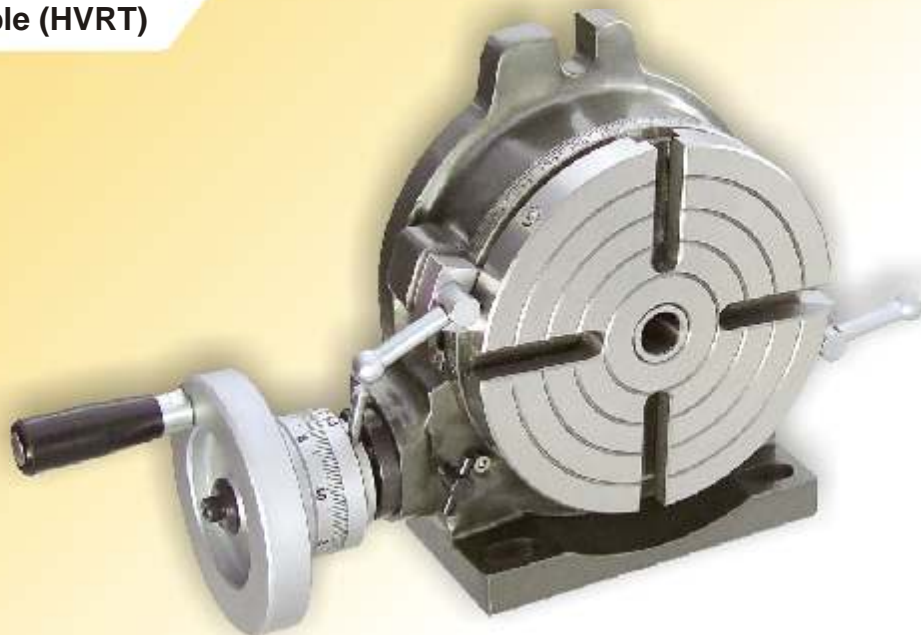

OPERATION AND SERVICE MANUAL

Horizontal & Vertical
Rotary Table (HVRT)



Horizontal & Vertical
2 Direction Rapid Indexer



HORIZONTAL
AND
VERTICAL



ROTARY TABLE

This Horizontal & vertical table is so designed as to permit machining operations at a higher dimension. The base can be used in a vertical position to enabling to carry out center work.

Order No. & Dimensions

Order No.	Table						Base dimension						Width of T-slat		Bolt slot		Center sleeve	Weight		Worm Gear ratio	
	Outer diameter				Height		H1		A		B		e		Type	g		Kg	lb		
	A1		D		H		Inch		mm		Inch		mm			Inch					mm
	Inch	mm	Inch	mm	Inch	mm	Inch	mm	Inch	mm	Inch	mm	Inch	mm	Type	Inch		mm			
110239	2.56	65	4.33	110	3.00	76	2.83	72	5.67	144	5.12	130	0.47	12	⊕	0.75	19	MT-2	7	18.7	90:1
110242	3.00	76	5.91	150	3.03	77	3.94	100	7.87	200	6.30	160	0.39	10	⊕	0.59	15	MT-2	12	26.4	90:1
110243	3.94	100	7.87	200	4.13	105	5.31	135	10.43	265	8.66	220	0.47	12	⊕	0.67	17	MT-3	26	57.2	90:1
110244	4.33	110	9.84	250	4.53	115	6.50	165	12.80	325	11.02	280	0.47	12	⊗	0.67	17	MT-3	48	105.8	90:1
110245	5.32	130	11.81	300	5.32	135	7.68	195	15.27	388	12.99	330	0.55	14	⊗	0.71	18	MT-4	74	162.8	90:1

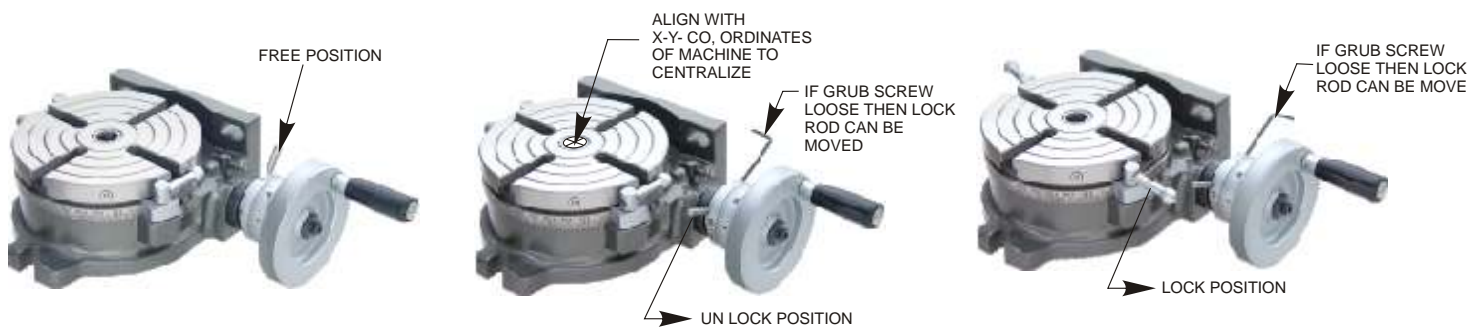
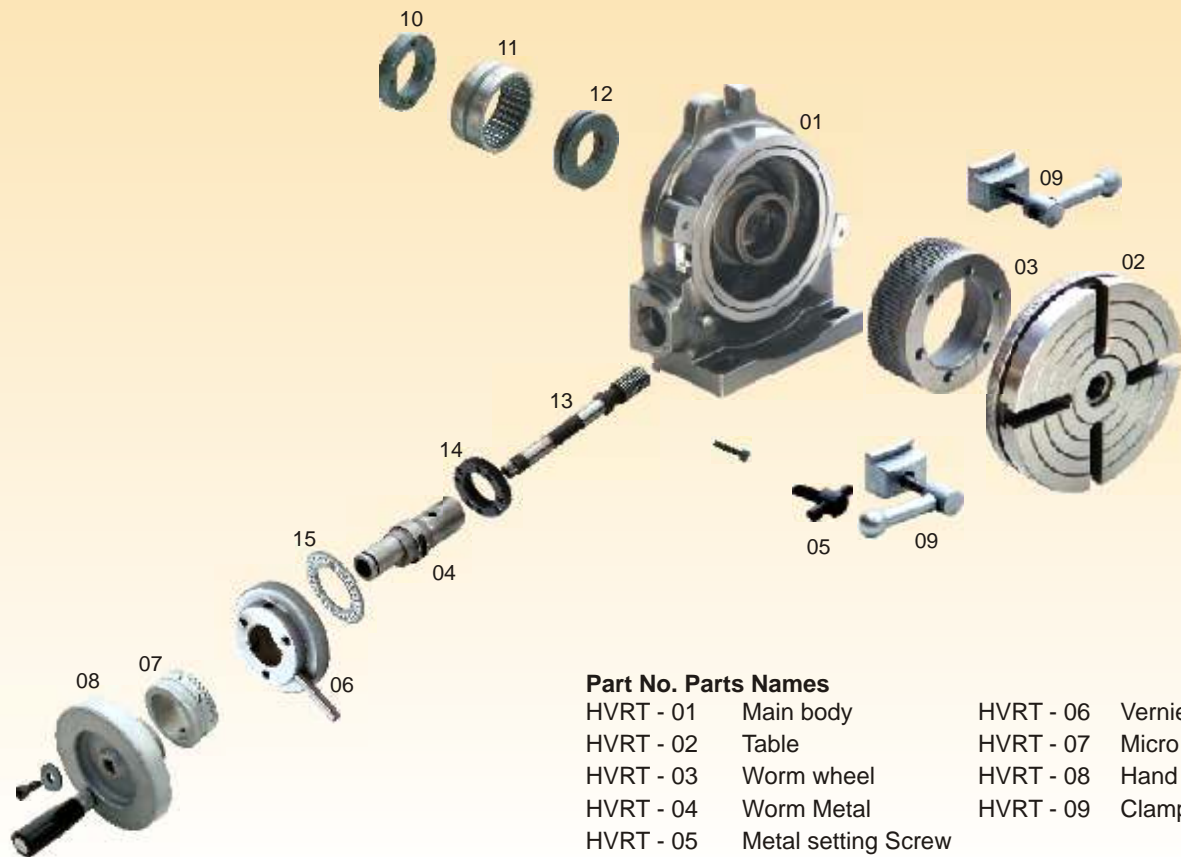

OPERATING INSTRUCTION AND FUNCTION OF EACH UNIT

1. The worm gear is 1: 90.
 - One turn of the handle moves the table by 4"
 - Micro - collar is graduated in steps of 1 min.
 - Vernier scale makes settings down to 10 seconds possible (20 seconds for 110242)
2. Dividing of 2 to 100 can be carried out quickly and accurately by attaching a Dividing Mechanism.
3. Center work can also be carried out by using the base in the vertical Position in conjunction with a tailstock.

THERE ARE THREE METHODS OF SETTING POSITIONS USING A ROTARY TABLE

1. Use the degree scale on the outer edge of the table (scale reading = 1 degree)
 - a To use the degree scale on the table top, disengage the worm by unlocking the T screw and rotating the pin on the worm collar clockwise. The table can be rotated by hand and can be locked in any position using the lock clamps.
2. Use the degree handwheel (scale on handwheel = degrees and minutes)
 - a To use the handwheel, unlock or loosen the T screw and rotate the pin on the worm collar anti-clockwise and when the worm has engaged, lock or tighten the T screw. If the worm collar will not rotate easily, it may be necessary to rotate the handwheel while keeping pressure on the pin so the worm will mesh or engage. The hand wheel is divided into degrees and minutes eg: 4 degrees per revolution or ratio of 90:1. The minute divisions on the handwheel can be further divided into 20 seconds using the vernier scale.
3. Use the index method (use index plates and refer index table)
 - a To use the index method first refer to the index table to select the index plate with the correct holes on the circle. (See Index table located on the Page-6 back of this manual)
 - b To use the index plates, the hand wheel must be removed by loosening the centre retaining screw and washer.
 - c Mount the appropriate index plate with the correct number of holes to the collar with 3 screws.
 - d Next fit the sector arms (the brass pieces) and adjust the sector arms for the correct number of holes. Holes are counted after the pin or first hole. So for six holes, sector arms are actually set for seven holes ie; pin + 6 holes.
 - e Fit the retaining washer in the groove in front of the sector arms.
 - f Fit the crank with the spring loaded handle, adjusting so the plunger lines up with the correct circle of holes. Tighten with the screw and washer that held the handwheel.
 - g To index, rotate the handle the correct number of full turns and then using the sector arms to measure the number of holes. After the handle is locked in, rotate the arms ready for the next cycle or index.

Eg: For 21 tooth gear or 21 divisions, Use the 21 hole plate. Set the sector arms for 6 holes then rotate the handle 4 full turns plus 6 holes. If in doubt, have a practice run

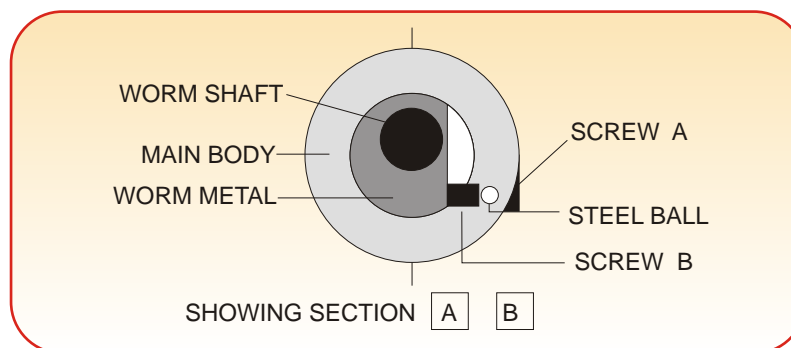

1. **Adjusting Mesh of worm Gear:-** Loosen the metal clamp handle and turn the switch metal clockwise until it touches the stopper. The worm gear has now been disengaged. Turn it counterclockwise until it touches the stopper, the worm and gear wheel will engage. Tighten the metal clamp handle after engagement. An additional adjustment can be obtained by removing the screw [A] and steel ball and turning the inner screw [B] counter clock-wise so bringing the worm in closer engagement with the gear wheel. Turning clock-wise brings the worm away from the wheel. After adjustment insert the steel ball and tighten screw [A]
2. **Axial Adjustment of Worm shaft:-** When axial slack occurs gear adjustment is carried out by tightening the inside worm shaft nut after the handle, vernier ring and switch metal have been removed. After adjustment, lock the nut on the shaft by means of the set screw. (The ROTARY TABLE has an adjustment, nut, which can be used after removal of the handle.)

SPECIAL ACCESSORIES

TAIL STOCK

The height can be varied when working with different index centers, while the angle of inclination can be changed for various machining applications. In addition, the tip of the center is finely rotatable. Clamping is made by tightening of bolts

Order No. & Dimensions for Tail Stock Unit mm/in.

Order No.R	Center Height				Suitable for
	Maximum		Minimum		
	Inch	mm	Inch	mm	
111301	3.94	100	3.15	80	110239, 110242, 110280, 110285
110247	6.53	200	4.05	135	110243 110244
110248	8.26	210	6.29	160	110245
111304	3.27	83	2.20	56	111300, 110240, 111305, 111310 110275



DIVIDING MECHANISM

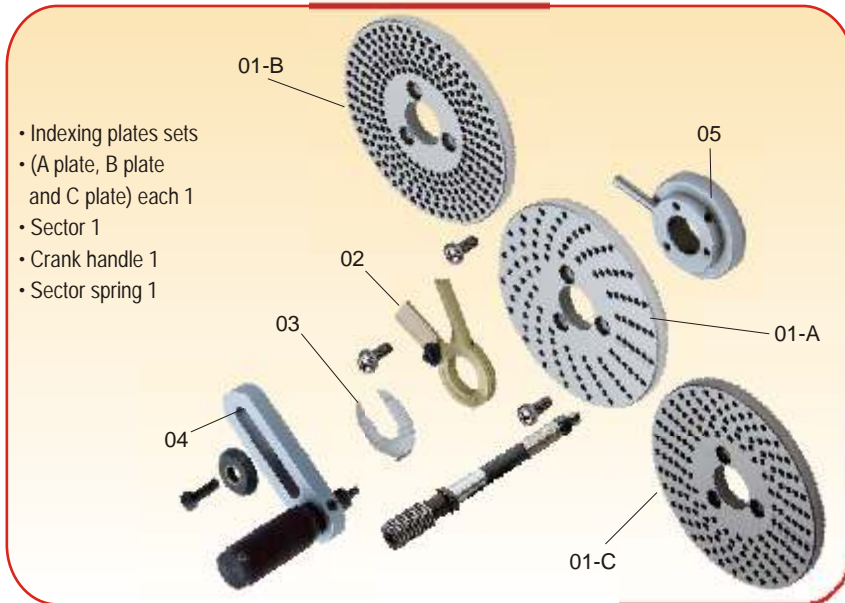

DIVIDING MECHANISM & INDEXING PLATES

Indexing Plates

Simple indexing consists of a series of preset holes in a backing plate, these divisions are provided for the most common angles (such as 90°, 45° and 30°). The remaining divisions of a circle are provided by manually rotating the dividing arm using index plates. Tables or calculations are required to use this method.

Order No. & Dimensions

Order No.	Dividing plate set screw	Major dimension of DM						Weight		Shipping Measurement ft	Indexing Plates
		Inner diameter of sector arm		Outer diameter of spring clip		Grove width in handle plate		Kg	lb		
		Inch	mm	Inch	mm	Inch	mm				
110260	32 PCD. 1.26Ø	0.83	21	0.71	18	0.03	9	2.5	5.51	0.12	3
110265	(3holes) 46 PCD. 1.81	1.12	28.7	1.73	44	0.39	10	4	8.82	0.12	2
110270	(3holes) 46 PCD. 1.81	1.12	28.7	1.73	44	0.39	10	4	8.82	0.12	2

SOME POSSIBLE USES OF A ROTARY TABLE

- Cutting gears
- Machining hex or square on a shaft
- Drilling holes equal distance around a circle eg holes in a flywheel
- Used as an adjustable angle plate - eg machine one face then rotate 90° degrees and machine the next face
- Milling a radius or an arc
- Create wheels with spokes by using the rotary table to machine out the triangular shaped holes in a wheel

IN CASE OF AN OPTIONAL DM DEVICE ATTACHED

Indexing of 2 to 100 can be made accurately and quickly.

Equation of Indexing

Since the worm ratio is 1 : 90, when the handle is made to rotate a 360° revolution, the table therefore will rotate a 1/90 revolution. The relationships between handle revolution 'N' and divisional number 'T' to be sought are shown in the following equation:

$$N = \frac{90}{T}$$

Remarks: The index table on Page-6 is made on the basis of this equation.

(Example)

In case where the operator wants to index the position divided into 29 equal parts. Hints on operation As for 29 divisional numbers, the number of crank handle revolutions (N) is 9/87 as shown in the table on Page-6 so that the handle should be rotated a full 360° revolution three times plus an interval of nine holes. (in this time, it means hole intervals not hole numbers). After setting this point as a start point, rotate the handle a full 360° revolution three times plus an interval of nine holes. When the procedure is repeated in turn as many as 29 times, the indexing of dividing into 29 equal parts is thus achieved.

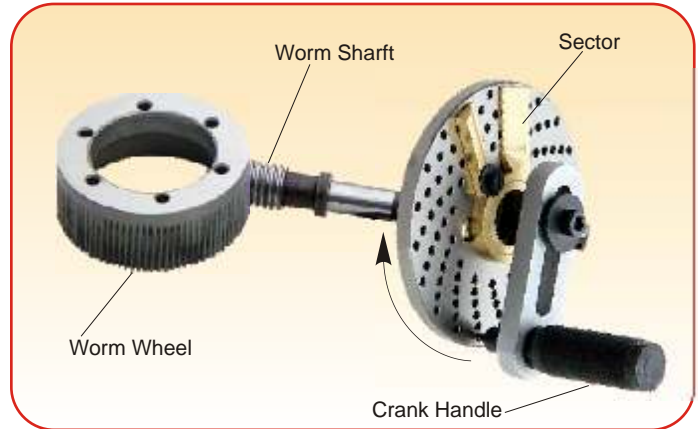

OPERATIONS OF CRANK HANDLE AND SECTOR

In case of Example 'Division into 29 Equal Parts' aforesaid, it is natural that indexing operation should proceed with the intervals of nine holes after setting the index plate (B plate) on which a row of 87 holes are provided. But in this method, the operator has to count nine holes' intervals one by one. He must feel inefficient. In this viewpoint, it is necessary to use a device called 'sector' to avoid such troublesome procedures. The following will describe some necessary procedures for operation of the sector.

- Loosen the crank handle lock nut, adjust its length so as to cause the index, pin to fall in the train of 87 holes, and retighten it.
- Loosen the set-screws of the sector, open two arms in accordance with the interval of nine holes (total numbers of holes are ten), and retighten with set-screws.
- First, bring the left arm of the sector near to the index pin's left side.
- Next, rotate the crank handle clock-wise to apply it to the right arm of the sector so that the index pin will fall in the hole located at this right arm's left side surface.
- Rotate the sector clockwise this time, and put the right side surface of the left arm to the side surface of the left arm to the left side of the index pin. In this time, the relationships between the index pin and the sector's left arm in their positions are the same as in Par. c). The index plate hole that actually accommodates the index pin is located at the point where goes across ten holes to the right away from the hole as in Par. c)
- Repeat the same procedures as necessary.



OPERATORS RESPONSIBILITY: -

Please take the time to read the users instructions.

Descriptive notations in our catalogue and discussions with staff are offered as a guide only. Purchasers must satisfy themselves as to

- The suitability of the product for their particular application and
- The process by which the product is used.

1. 3 Jaw chuck fitted Head The big range clamping capacity.
2. Dividual number 24-notch (15° each)
3. Table scale 1°, for angular indexing
4. Horizontal / Vertical & 2 direction
5. Suit for milling & drilling machine using
6. Optional: Tailstock Nr 110240



111301

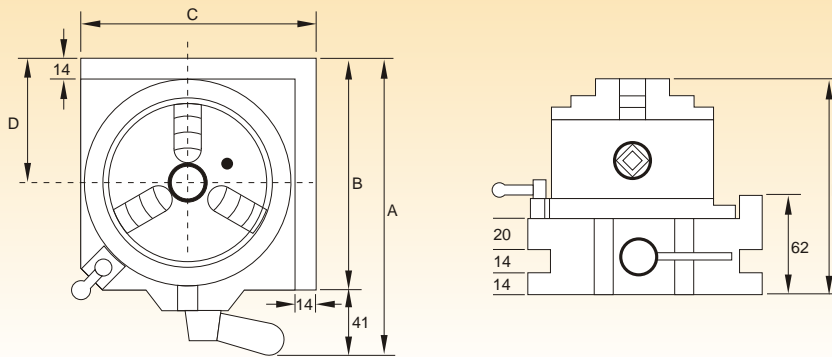

CHARACTERISTIC

Useful for 2 Direction horizontal & Vertical milling and drilling operations. It has a 3 Jaw chuck fitted on the head for big range clamping. The indexer has a simple rapid operation with Dividual number 24 - notch (15° each) and a Table scale of 1° for angular indexing.

RAPID INDEXER

Order Nr.	A		B		C		D		E		Weight Kg.
	Inch	mm	Inch	mm	Inch	mm	Inch	mm	Inch	mm	
110275	6-3/8	160	4-3/4	120	4-3/4	120	2-3/16	55	5	120	6.3
110280	7-3/8	185	5-3/4	145	5-3/4	145	2-5/8	66	5-3/8	135	9.3
110285	8	200	6-3/8	160	6-3/8	160	3-3/16	80	6-3/16	155	14



Horizontal & Vertical Rotary Table (HVRT)

INDEX TABLES FOR 6" , 8" , 10" & 12" HORIZONTAL / VERTICAL ROTARY TABLE 90:1 RATIO

DP - 1 for HV-6

DP - 2 for HV-8 DP - 3 for HV-10, 12

Number	Plate and Circle	Complete Turns	Part of Turn
1	ANY	90	
2	ANY	45	
3	ANY	30	
4	A20	22	10/20
5	ANY	18	
6	ANY	15	
7	B21	12	18/21
8	A20	11	5/20
9	ANY	10	
10	ANY	9	
11	B33	8	6/33
12	A20	7	10/20
13	C39	6	36/39
14	B21	6	9/21
15	ANY	6	
16	A16	5	10/16
17	A17	5	5/17
18	ANY	5	
19	A19	4	14/19
20	A20	4	10/20
21	B21	4	6/21
22	B33	4	3/33
23	B23	3	21/23
24	A20	3	15/20
25	A20	3	12/20
26	C39	3	18/39
27	A18	3	6/18
28	N/A		
29	B29	3	3/29
30	ANY	3	
31	B31	2	28/31
32	A16	2	13/16
33	B33	2	24/33
34	A17	2	11/17
35	B21	2	12/21
36	A20	2	10/20
37	C37	2	16/37
38	A19	2	7/19
39	C39	2	12/39
40	A20	2	5/20
41	C41	2	8/41
42	B21	2	3/21
43	C43	2	4/43
44	N/A		
45	ANY	2	
46	B23	1	22/23
47	C47	1	43/47
48	A16	1	14/16
49	C49	1	41/49
50	A20	1	16/20

Number	Plate and Circle	Complete Turns	Part of Turn
51	N/A		
52	N/A		
53	N/A		
54	A18	1	12/18
55	B33	1	21/33
56	N/A		
57	A19	1	11/19
58	B29	1	16/29
59	N/A		
60	A20	1	10/20
61	N/A		
62	B31	1	14/31
63	B21	1	9/21
64	N/A		
65	C39	1	15/39
66	B33	1	12/33
67	N/A		
68	N/A		
69	B23	1	7/23
70	B21	1	6/21
71	N/A		
72	A20	1	5/20
73	N/A		
74	C37	1	8/37
75	A20	1	4/20
76	N/A		
77	N/A		
78	C39	1	6/39
79	N/A		
80	A16	1	2/16
81	A18	1	2/18
82	C41	1	4/41
83	N/A		
84	N/A		
85	N/A		
86	C43	1	2/43
87	B29	1	1/29
88	N/A		
89	N/A		
90	ANY		
91	N/A		
92	N/A		
93	B31		30/31
94	C47		45/47
95	A19		18/19
96	A16		15/16
97	N/A		
98	C49		45/49
99	B33		30/33
100	A20		18/20

Number	Plate and Circle	Complete Turns	Part of Turn
2	ANY	45	
3	ANY	30	
4	A26	22	13/26
4	A28	22	14/28
5	ANY	18	
6	ANY	15	
7	A28	12	24/28
7	B77	12	66/77
8	A28	11	7/28
8	A44	11	11/44
9	ANY	10	
10	ANY	9	
11	A44	8	8/44
11	B77	8	14/77
12	A26	7	13/26
12	A28	7	14/28
13	A26	6	24/26
13	B91	6	84/91
14	A28	6	12/28
14	B77	6	33/77
15	ANY	6	
16	A32	5	20/32
17	A34	5	10/34
18	ANY	5	
19	A38	4	28/38
20	A26	4	13/26
20	A28	4	14/28
21	A28	4	8/28
21	B77	4	22/77
22	A44	4	4/44
22	B77	4	7/77
23	A46	3	42/46
23	B69	3	63/69
24	A28	3	21/28
24	B44	3	33/44
25	A30	3	18/30
26	A26	3	12/26
26	B91	3	42/91
27	A30	3	10/30
27	B63	3	21/63
28	A28	3	6/28
29	B87	3	9/87
30	ANY	3	
31	B93	2	84/93
32	A32	2	26/32
33	B99	2	72/99
34	A34	2	22/34
35	A28	2	16/28
35	B63	2	36/63
36	A26	2	13/26
36	A28	2	14/28
37	A37	2	16/37
38	A38	2	14/38
39	A26	2	8/26
39	B91	2	28/91
40	A28	2	7/28
40	A44	2	11/44
41	A41	2	8/41
42	A28	2	4/28
42	B63	2	9/63
43	A43	2	4/43
44	A44	2	2/44
45	ANY	2	
46	A46	1	44/46
46	B69	1	66/69
47	A47	1	43/47

Number	Plate and Circle	Complete Turns	Part of Turn
48	A32	1	28/32
49	A49	1	41/49
50	A30	1	24/30
51	A34	1	26/34
52	A26	1	19/26
53	A53	1	37/53
54	A30	1	20/30
54	B63	1	42/63
55	A44	1	28/44
55	B77	1	49/77
56	A28	1	17/28
57	A38	1	22/38
58	B87	1	48/87
59	A59	1	31/59
60	A34	1	17/34
60	A32	1	16/32
61	B61	1	29/61
62	B93	1	42/93
63	A49	1	21/49
63	B77	1	33/77
64	A32	1	13/32
65	A26	1	10/26
65	B91	1	35/91
66	A44	1	16/44
66	B99	1	36/99
67	B67	1	23/67
68	A34	1	11/34
69	A46	1	14/46
69	B69	1	21/69
70	A28	1	8/28
70	B63	1	18/63
71	B71	1	19/71
72	A32	1	8/32
72	A44	1	11/44
73	B73	1	17/73
74	A37	1	8/37
75	A30	1	6/30
76	A38	1	7/38
77	B77	1	13/77
78	A39	1	6/39
78	B91	1	14/91
79	B79	1	11/79
80	A32	1	4/32
81	B63	1	7/63
81	B81	1	9/81
82	A41	1	4/41
83	B83	1	7/83
84	A28	1	2/28
85	A34	1	2/34
86	A43	1	2/43
87	B87	1	3/87
88	A44	1	1/44
89	B89	1	1/89
90	ANY	1	
91	B91		90/91
92	A46		45/46
93	B93		90/93
94	A47		45/47
95	A38		36/38
96	A32		30/32
97	B97		90/97
98	A49		45/49
99	A44		40/44
99	B99		90/99
100	A30		27/30

Description of In the index table.

This table is the one being calculated for the index plate with hole number shown below.

NUMBER OF HOLES

DP-1

A Plate.....15, 16, 17, 18, 19, 20
 B Plate.....21, 23, 27, 29, 31, 33
 C Plate.....37, 39, 41, 43, 47, 49

DP-2 & 3

A Plate.....26, 28, 30, 32, 34, 37, 38, 39, 41, 43, 44, 46, 47, 49, 51, 53, 57, 59
 B Plate.....61, 63, 67, 69, 71, 73, 77, 79, 81, 83, 87, 89, 91, 93, 97, 99

For index numbers greater than 10, use formula

Machine Tool Accessories

Horizontal / Vertical Rotary Tables



Precision Machine Vises



- Vises
- Engineering & Cutting Tools
- Drill Sleeves & Sockets
- Boring Heads & Tool Holders
- Tool Bits, Reamers & Endmills
- Measuring Tools
- Plate Shears
- Punches & Chisels
- Woodworking Tools
- Boring Bars
- Micro Boring Tools
- Endmills
- Turning Tools
- E-Boring Bars